

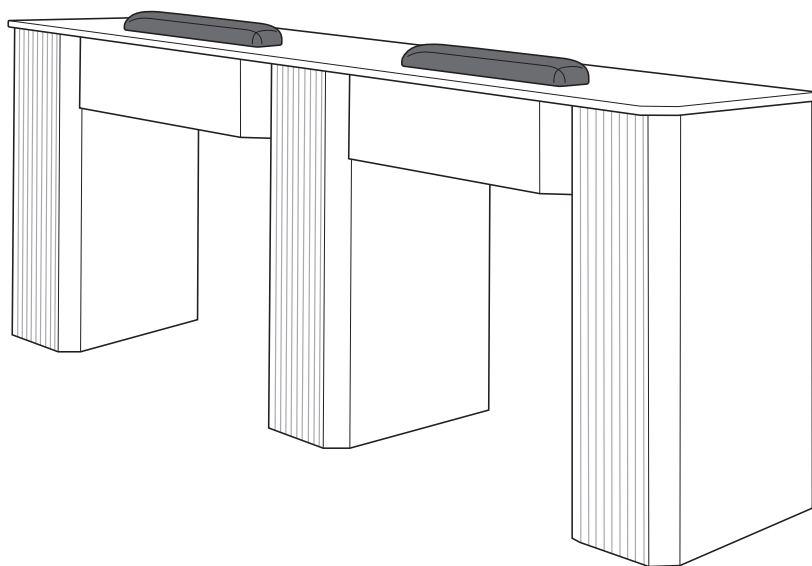

# Vanilla

## Double Table









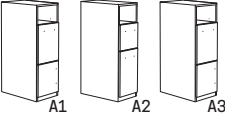

## User Manual

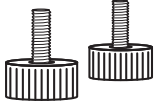
---

Ergonomic and elegant  
manicure double table

# ASSEMBLY

<p><b>A (x3)</b> Table Legs</p> 	<p><b>B (x2)</b> Top Drawers</p> 	<p><b>C (x1)</b> Trash Bin</p> 	<p><b>D (x12)</b> Rubber Feet</p> 
<p><b>E (x16)</b> M3x6 Screw &amp; Washer</p> 	<p><b>F (x1)</b> Key Wrench</p> 	<p><b>G (x8)</b> Pull Handles</p> 	<p><b>H (x2)</b> Countertop Stones</p> 
<p><b>I (x2)</b> Hand Rest Cushions</p> 			

## 1. Unpack the components

The Top Drawers (B) are delivered fastened together with screws inside the packaging to prevent damage during transport. Remove the screws and separate the drawers before beginning assembly.

Locate the Trash Bin (C) in the lower drawer of the second Table Leg (A2). All components required for assembly are contained inside the trash bin.

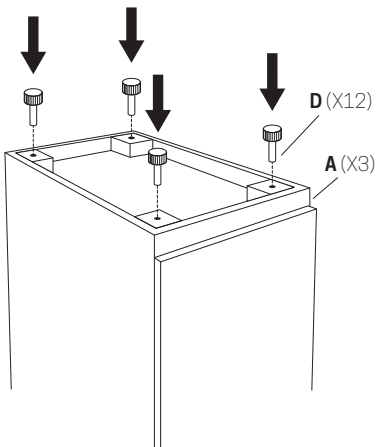
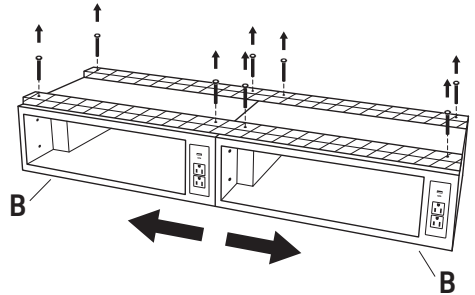

## 2. Attach Rubber Feet

Insert the Rubber Feet (D) into the 4 holes at the bottom of each Table Leg (A).

### 3. Assemble Table Legs to Top Drawers

Attach the three Table Legs (A) to the two Top Drawers (B) using the Screws (E) and the Key Wrench (F).

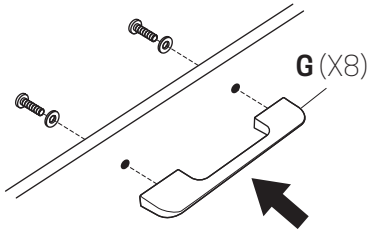
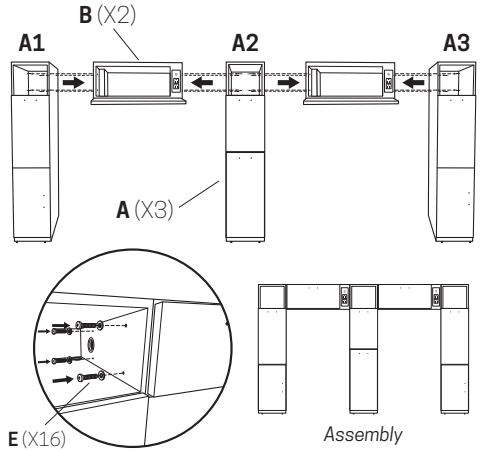

### 4. Assemble Pull Handles

Pull Handles (G) arrive fastened on the inside protect them during transport. Unscrew all Pull Handles and reattach them facing to the outside.

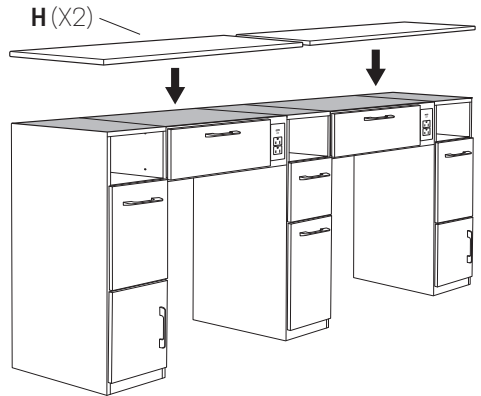

### 5. Recommended: Fasten Countertop

Secure the two Countertop Stones (H) to the top of the table using glue or silicon (not included).

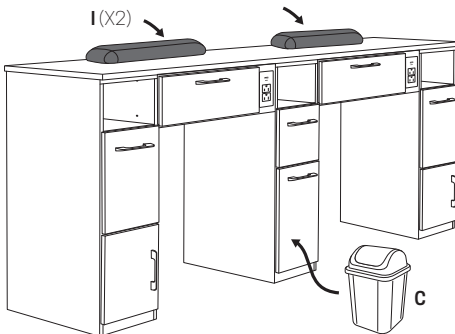

### 6. Finished assembly

The table is now fully assembled.

Place the Trash Bin (C) back into its drawer and position the Hand Rest Cushions (I) on the countertop.

## FEATURES

### 1 | Elegant Design

Elevates your saloon style with an elegant design with marble quartz countertop.

### 2 | Storage

Eight drawers and three open shelves to have everything you need close at hand.

### 3 | Power Hubs (x2)

Embedded power outlets available to connect from every drawer.

- 4 AC Outlets
- 2 Fast charging USB-A port
- 2 Fast charging USB-C port

### 4 | Trash Bin

Includes a concealed trash bin drawer to help maintain a clean and tidy workstation.

### 5 | Rubber Feet

Heavy duty rubber feet. Provide a stable support while protecting table and floor from scratches and wear.

### 6 | Hand Rest Cushion (x2)

PU, acetone resistant nail cushion accessories.

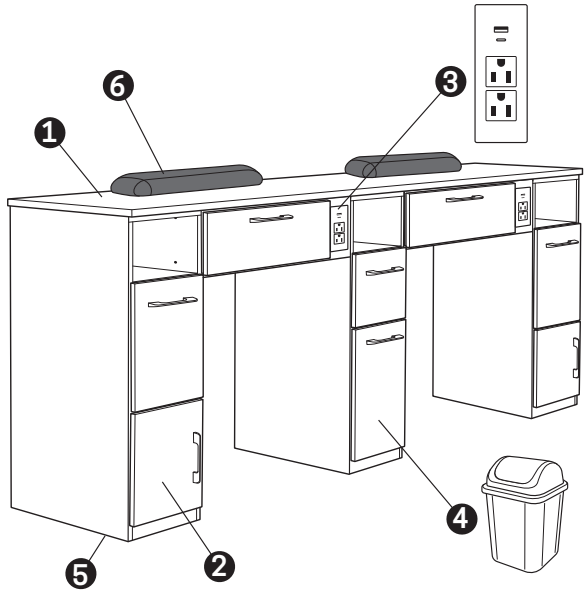

## MAINTENANCE RECOMMENDATIONS

- Clean the table and all accessories after each service using an appropriate cleaning solution or sanitizer.
- With intensive, high-volume use, some components —such as drawer hardware and rubber feet— may wear down over time. Perform regular inspections of the table and its components to detect early signs of wear, and replace parts as needed. Routine maintenance will help extend the product's lifespan.
- Heavy use may also cause the countertop surface to wear or become damaged over time. Do not service clients on a cracked, chipped, or peeling countertop, as this may cause injury. If the countertop shows signs of deterioration, please contact Customer Service to arrange repair or replacement.

**T-Spa Customer Service:** 888-508-8772



#### RISK OF ELECTRIC SHOCK

Use only indoors in dry locations.



#### STATE OF CALIFORNIA PROPOSITION 65 WARNING

Product may contain chemicals known to the State of California to cause cancer or reproductive harm. For more information, go to [www.p65warnings.ca.gov](http://www.p65warnings.ca.gov)

Power outlet hub in compliance with safety standards:



# VENTILATION SYSTEM ALTERNATIVES

Manicure table ventilation system offered, produced and verified by T-SPA MFG LLC.

- Vent Head on Countertop Stones, Diameter: 4"
- Ventilation System Pipe, Diameter: 2"

## 1. Left & Right Side Air Vent System

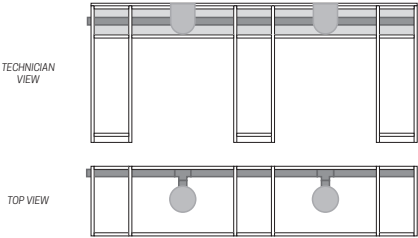

## 2. Left Side Air Vent System

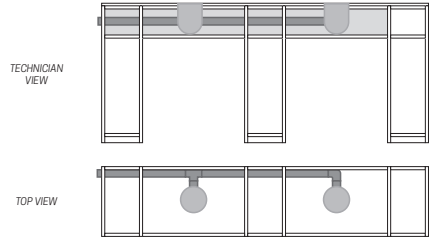

## 3. Right Side Air Vent System

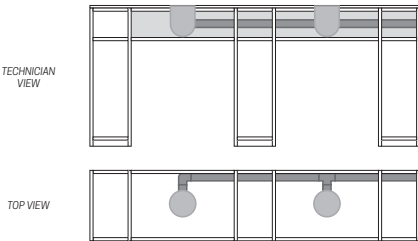

## 4. Down Left Leg Air Vent System

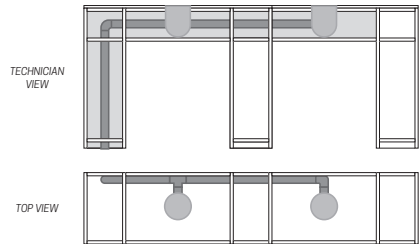

## 5. Down Right Leg Air Vent System

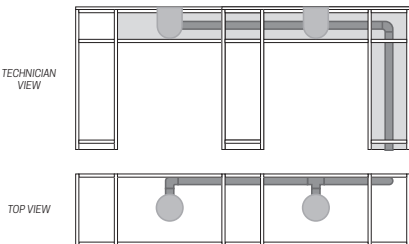

## 6. Down Middle Leg Air Vent System

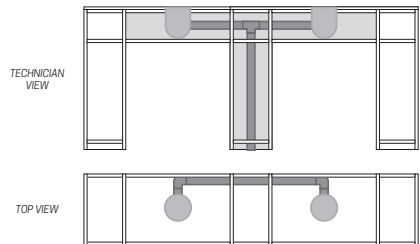

TECHNICAL SPECIFICATIONS		
Dimensions	Height	30.5" (78 cm)
	Length	74" (188 cm)
	Width	17" (43 cm)
Knee clearance width	22.75" (56 cm)	
Weight	235 lb (108 kg)	
Acetone resistant	Yes	
Color	Beige	
Countertop material	Marble Quartz	
Power outlet hubs (2)	4 AC Outlets 12A 125V AC 60Hz 1500W	
USB charger	2 USB-A & 2 USB-C Ports 5V 2A Max	
Assembly required	Yes (all required tools included)	
Trash bin	1 Included	
Hand rest cushions	2 Included	
Ventilation system	Optional upgrade	
Warranty	6 Months	

**T-SPA<sup>®</sup>**  
**WWW.TSPALLC.COM**

T-SPA MFG, LLC  
10510 Kinghurst Dr  
Houston, TX 77099  
1(888)508-8772  
Info@tspallc.com