

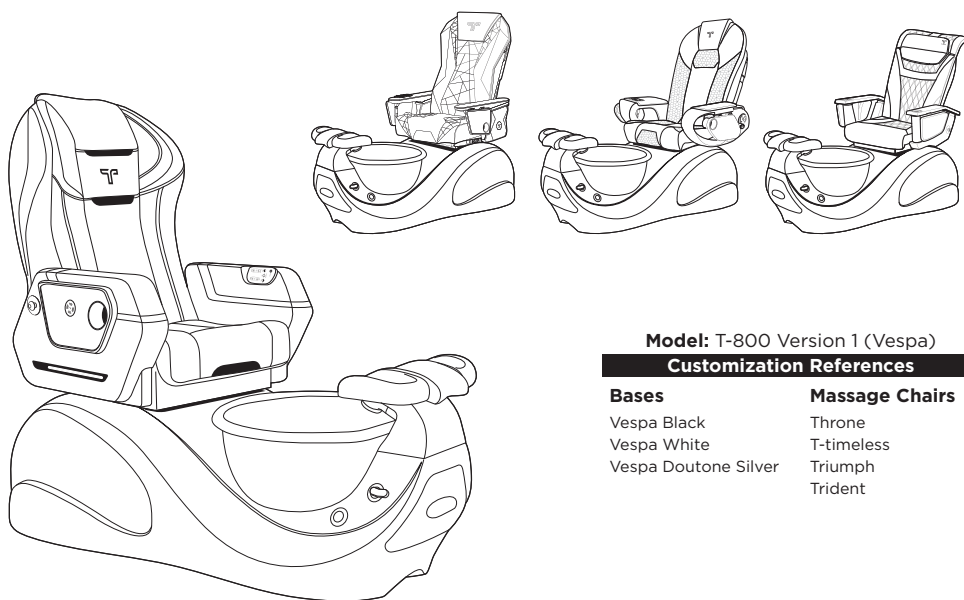

# Vespa

## Pedicure Spa



**Model: T-800 Version 1 (Vespa)**

### Customization References

#### Bases

Vespa Black  
Vespa White  
Vespa Doutone Silver

#### Massage Chairs

Throne  
T-timeless  
Triumph  
Trident

# User Manual

Read this manual before using the unit  
and keep it for future reference.

# INTRODUCTION

Thank you for your purchase!

Your new spa pedicure chair will be key in making a striking first impression on your clients, and your aid in providing memorable experiences that will make them your recurring customers.

T-SPA pedicure spas are designed to provide high-end, luxury pedicure experiences. T-SPA pedicure spas include many features that are sure to satisfy the most discerning clients, such as seat controls, hand cut and sewn upholstery, sumptuous tubs, and full massage systems.

T-SPA pedicure spa units are designed for licensed therapists and technicians and are intended to be used in a professional spa, salon, or similar commercial environment. While no special training is needed to operate the product, for safety reasons it is important that the instructions contained in this manual are reviewed in detail before the first use.

This manual should be read in its entirety by each professional who will be operating the product to ensure the safety of both operator and client.

This manual should be saved for future reference.

Your T-SPA pedicure spa unit should not be used in any other manner than described in this manual. Please read, understand, and follow all safety warnings, labels, and instructions. Misuse, use of unnecessary force, or using the chair for unintended or unauthorized procedures can result in injury to operator, client, and/or equipment.

Detailed instructions for use and maintenance can be found in this user manual. If you have further questions, please contact us at (888) 508-8772, or send us a fax to (832) 230-5486. We can also be reached via e-mail at [info@tspallic.com](mailto:info@tspallic.com)

This product in whole is in compliance with applicable UL® LISTED standards and requirements for the U.S. and Canada by Underwriters Laboratories Inc.



Some of the components of this product are in compliance with applicable safety standards



Plumbing system in compliance with



© T-SPA 2024, All Rights Reserved. Design and Specifications are subject to change without notice.

# TABLE OF CONTENTS

<b>INTRODUCTION</b>	<b>2</b>
<b>SAFETY INFORMATION</b>	<b>4</b>
SHIPMENT INSPECTION	4
HEALTH RISKS	4
RESPONSIBLE USE	6
<b>PEDICURE SPA SPECIFICATIONS</b>	<b>7</b>
<b>COMPONENTS</b>	<b>8</b>
<b>INSTALLATION</b>	<b>10</b>
INSTALLATION REQUIREMENTS	10
CHAIR ASSEMBLY TO SPA BASE	11
PLUMBING INSTALLATION	12
WIRING	14
TESTING AFTER INSTALLATION	15
<b>PEDICURE SPA OPERATION</b>	<b>16</b>
<b>CLEANING AND MAINTENANCE</b>	<b>20</b>
<b>TROUBLESHOOTING</b>	<b>22</b>
<b>LIMITED WARRANTY</b>	<b>23</b>
<b>LIMITED WARRANTY REGISTRATION FORM</b>	<b>25</b>
<b>APPENDIX</b>	<b>26</b>

# SAFETY INFORMATION

## IMPORTANT SAFETY INSTRUCTIONS - FOR COMMERCIAL USE ONLY

Read all instructions before using this product.

### SHIPMENT INSPECTION

Thoroughly inspect the components immediately upon arrival to make sure no damages to the pedicure spa tub and chair occurred during the shipment. It is very important that you notify the driver directly and note any damage or irregularities on the delivery receipt. Failure to note damage on the delivery receipt may prevent any claims you may have against the carrier.

#### Shipping Damage Claim

If concealed loss or damage is found, you MUST report it to T-SPA's Customer Support within 24 hours after receiving the products.

#### Do Not Discard The Shipping Carton

Failure to do so constitutes acceptance of the shipment as-is and in good order and, additionally, waives any right to collect possible compensation from shipping claims.

### INSTALLATION WARNINGS

Our pedicure spa units must be installed by licensed professionals. Every unit must be installed by licensed plumbers and licensed electricians. Installation MUST be in compliance with all local and state building codes.



#### RISK OF ELECTRIC SHOCK

Connect only to a circuit protected by a ground-fault circuit-interrupter (GFCI).

Grounding is required. This unit must be installed by a licensed electrician and grounded.

Should the unit malfunction or break down, grounding provides a path of least resistance for electric current to reduce the risk of electric shock. This unit's power cord is has an equipment-grounding conductor and grounding plug. The plug must be connected to an appropriate outlet that is properly installed and grounded in accordance with all local codes and ordinances.

Improper connection of the equipment-grounding connector can result in a risk of electric shock. Check with a qualified electrician if you are in doubt as to whether the product is properly grounded. Do not modify the plug provided with the product if it will not fit your outlet, have a proper outlet installed by a qualified electrician.

This unit cannot operate efficiently or safely unless it is provided with adequate electrical power, sufficient water pressure, proper water temperature, and required drainage capabilities. This pedicure spa unit should only be operated in a room temperature between 40°F (4°C) and 100°F (38°C). DO NOT use it outdoors or in excessively humid or dusty environments.

Contact your local building inspector for information and local code compliance procedure that need to be followed when having your new pedicure spa unit installed. You are responsible to ensure that all plumbing connections meet national, state and local code.

Subsequent inspections and approvals that may be required are the responsibility of the purchaser.

### HEALTH RISKS

Those under a doctor care or who are experiencing one or more of the following conditions should consult their doctor before using the pedicure spa. Failure to do so may result in accidents and health problems.

- You are receiving medical treatment or are feeling ill.
- Your body shows any acute symptoms.
- You have been diagnosed with a malignant tumor or heart disease.
- You are pregnant or menstruating.
- Your doctor has ordered you to rest.
- You have a back disorder resulting from an accident or disease.
- You have high fever.
- You have sensory disorders.
- You have a medical electrical device (e.g. pacemaker).
- You have an open wound.
- You have poor circulation in your legs or feet. Some signs of poor circulation are numbness, tingling, and pain.
- You have a fungal infection.
- You are diabetic.
- You have any swelling, fractures, persistent pain.



### WARNING - HEALTH HAZARD

It is important that you carefully follow the basin cleaning procedures as described on page 20 to ensure that the spa is sanitized after each use.

T-SPA is not liable for any infections or disease that may result from improper cleaning or failure to adhere to sanitation requirements. Misuse or failure to properly clean the spa unit may result in serious health issues and/or severe disease contagion.

Do not massage any area of the body that is swollen, inflamed, or covered with skin eruptions.

Advise clients to drink a glass of water after a massage session, this helps improve circulation.



### WARNING - POTENTIAL HAZARDS

Risk of accidental injury or drowning. Do not use drugs or alcohol before or during use. Children or handicapped persons should not use without supervision.

Risk of hyperthermia and possible drowning. Water temperature in excess of 38°C or 100.4°F can be harmful to your health. Check and adjust water temperature before use.

Hyperthermia occurs when the internal temperature of the body reaches a level several degrees above the body temperature of 98.6°F or 37°C. The symptoms of hyperthermia include an increase in the internal temperature of the body, dizziness, lethargy, drowsiness, and fainting. The effects of hyperthermia include:

- Failure to perceive heat.
- Failure to recognize the need to exit the hydro massage bathtub.
- Unawareness of impending hazard.
- Fetal damage in pregnant women.
- Physical inability to exit the hydro massage bathtub, and unconsciousness resulting in the danger of drowning.



### WARNING - ACCIDENT PREVENTION

Identify potentially hazardous situations to prevent accidents.

- **RISK OF HYPERTHERMIA** - The use of alcohol, drugs, or medication can greatly increase the risk of fatal hyperthermia.
- **RISK OF HYPERTHERMIA AND DROWNING** - Do not use a hydro massage bathtub with heater immediately following a strenuous exercise.
- **RISK OF ELECTRIC SHOCK** - Do not permit any electric appliances within 5 ft (1.5m) of the unit.
- **RISK OF INJURY** - Use this product for its intended purpose: a manicure chair and fill and drain indoor commercial appliance for foot and ankle hydro massage. DO NOT use attachments not recommended by manufacturer.
- **RISK OF INJURY OR DROWNING** - Ensure that all suction guards are installed to prevent body and hair entrapment.
- **MOVABLE PARTS, RISK OF INJURY** - Keep children away from the spa unit as it has movable parts that could cause an accident. Close supervision is necessary when this unit is used by, or near children, or disabled people. DO NOT leave children alone or allow them to operate the controls. Keep controls out of reach of children. DO NOT allow children to crawl behind the chair.
- **RISK OF FETAL INJURY** - Pregnant or possibly pregnant women should consult a physician before using a hydro massage bathtub equipped with heater.
- Hydrotherapy should be pleasant and comfortable. Should you experience any pain or discomfort while using the foot bath, discontinue use immediately and consult a physician.
- DO NOT use unit where aerosol (spray) products are being used or oxygen is being administered.
- **RISK OF BURNS, FIRE OR ELECTRICAL SHOCK** - Never leave the unit unattended while it is switched ON. Unplug it when it is not in use for an extended period. Always unplug it before installation, cleaning, or removal of parts.
- **RISK OF INJURY** - Do not put hands or fingers near the massage mechanism.
- **RISK OF INJURY** - Exercise care when entering or exiting the chair and foot bath.
- DO NOT overfill the basin.
- DO NOT stand on the basin, nor on the foot rest.
- DO NOT leave this appliance unattended when in operation.
- DO NOT use outdoors.
- BE CAUTIOUS when making positioning

adjustments to your chair. Keep all equipment and body parts away from moving parts while making any adjustments.

- Disconnect power supply cord before servicing and cleaning.
- Never use this unit if it has a damaged cord or plug, if it is not working properly, if it has been dropped or damaged, or dropped into water. Return the unit to a service center for examination and repair.
- DO NOT operate this unit if it is emitting noise above normal. If you notice that the unit is operating abnormally or malfunctioning, immediately turn off the power and disconnect the power cord from the outlet. Do not operate if it is not working properly.
- Keep the cord away from heated surfaces.
- Never operate the unit with blocked air openings. Keep the air openings free of lint, hair, etc.
- Never drop or insert any object into any opening.
- DO NOT reach for any electrical object that has fallen into the water. Unplug immediately.
- DO NOT drop or insert anything into jet opening.
- DO NOT operate without the complete jet assembly installed or without water filled 1 inch above jets.
- Connect this appliance only to a properly grounded outlet.
- Make certain that the cord and plug are maintained in good condition and are not allowed to become damaged while in use. Avoid positioning the cord in the traffic lane and it is always kept out of the way.
- Take this unit out of service immediately if the cord or plug becomes damaged in any way.
- Do not attempt to repair yourself. All repairs must be performed by an authorized service representative.
- Test the ground-fault circuit-interrupter protecting this appliance periodically in accordance with the manufacturer instructions.
- In the event of a power outage or a power failure, always turn the power switch to its OFF position. Always turn the switch OFF when not in use.



#### STATE OF CALIFORNIA PROPOSITION 65 WARNING

Product may contain one or more chemicals known to the State of California to cause cancer or reproductive harm. For more information, go to [www.p65warnings.ca.gov](http://www.p65warnings.ca.gov)

## RESPONSIBLE USE

For safety reasons it is important that the instructions contained in this manual are reviewed in detail before the first use. This manual should be read in its entirety by each professional who will be operating the product to ensure the safety of both operator and client. This manual should be saved for future reference.

Should not be used in any other manner than described in this manual. Please read, understand, and follow all safety warnings, labels, and instructions. Misuse, use of unnecessary force, or using the chair for unintended or unauthorized procedures can result in injury to operator, client, and/or equipment.

- The maximum weight capacity of the spa chair 250 lb (113 kg).
- Always enter and exit the pedicure spa slowly and carefully.
- Use only while seated.
- Do not stand in the pedicure basin.
- Check the water temperature before each use. Water temperature should NOT exceed 105°F (41°C). The supply water temperature should never exceed 140°F (60°C)
- Always connect this unit to a properly grounded electrical outlet.
- Do not use the massage chair for more than 15-minute periods.
- If there is severe discomfort during the massage, discontinue use and consult a physician.
- This unit is designed only to operate on a standard 110 Volt 60 Hz current. Exceeding this standard may cause injury and/or serious bodily harm and/or damage to property.
- Never drop or insert any object into any opening of the unit.
- Before operating the massage chair, make sure the chair arms are down.
- Keep the massage chair and its air openings clean and free of hair and dust; never operate the massage chair if the air openings are blocked.



#### WARNING - THERMAL RESETTING PROTECTION DEVICE

The massage chair is equipped with a thermal resetting protection device. This is a safety feature to protect it from overheating. If the chair should suddenly stop and will not start, turn the main power switch off, and do not operate the chair for at least 30 minutes. Failure to turn the chair off may result in the chair starting unexpectedly when the device cools.

# PEDICURE SPA SPECIFICATIONS

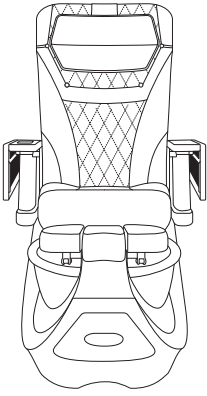

Vespa Base & T-timeless Chair

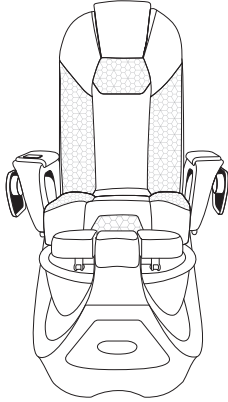

Vespa Base & Throne Chair

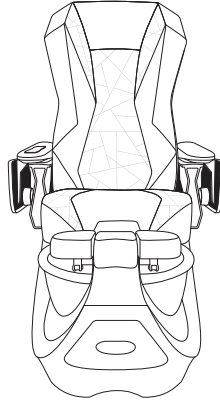

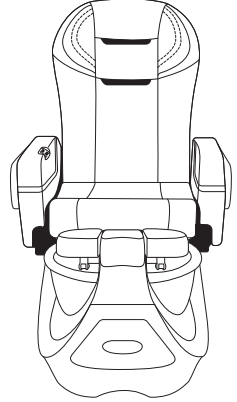

Vespa Base & Triumph Chair



Vespa Base & Trident Chair

## TECHNICAL SPECIFICATIONS

	Vespa/T-timeless	Vespa/Throne	Vespa/Triumph	Vespa/Trident
<b>Model</b>	T-800 Version 1 (Vespa)			
<b>Technician stool</b>	✓	✓	✓	✓
<b>Dimensions</b>	54" (74" fully reclined) L x 32" (48" extended manicure tray) W x 56" H			
<b>Weight</b>	270 lb (150 lb Spa Base - 120 lb Massage Chair)			
<b>Tub water capacity</b>	4.5 US gal			
<b>Maximum weight capacity</b>	250 lb			
<b>Lift-up Footrest</b>	✓	✓	✓	✓
<b>Seat heating</b>	-	-	✓	✓
<b>Base material</b>	Fiberglass			
<b>Basin material</b>	Glass			
<b>Purse hook</b>	1 Hook	2 Hooks	2 Hooks	2 Hooks
<b>USB charger</b>	1 USB terminal	2 USB terminals	2 USB terminals	Wireless charger
<b>Cup holder</b>	1 Cup holder	2 Cup holder	2 Cup holder	2 Cup holder
<b>Power source</b>	Dedicated 15 A wall outlet 120 V - 15 A - 60 Hz			
<b>Massage system</b>	120 V - 60 Hz			
<b>Water flow rate</b>	500 GPH			
<b>Jet system</b>	 /or/ 			(available for selection upon purchase)
<b>Discharge pump</b>	Optional upgrade (Power source 115 V - 3.2 A - 60 Hz)			
<b>Auto-fill</b>	Optional upgrade			
<b>Ventilation</b>	Optional upgrade			
<b>Thermometer shower head</b>	Optional upgrade			
<b>Importer</b>	T-SPA MFG, LLC			
<b>Manufacturer</b>	<b>Base</b>	Heshan Kangmei Health Technology Co.,Ltd		
	<b>Chair</b>	Foresee Sciencetech Ltd.		Irest Health Science and Technology Co.,Ltd

# COMPONENTS

Vespa / T-timeless

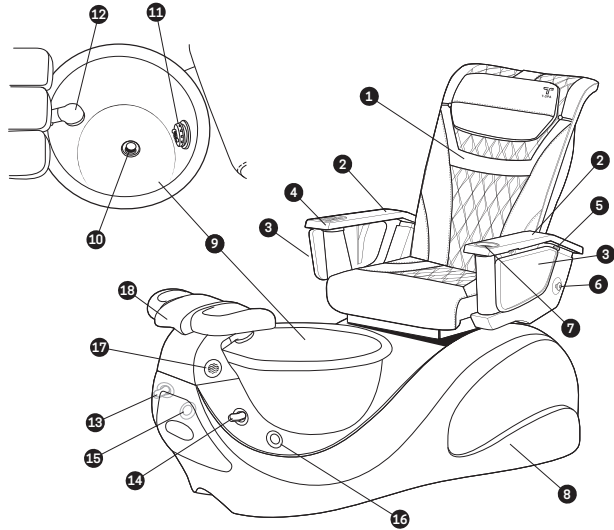
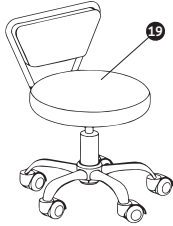

Vespa / Throne

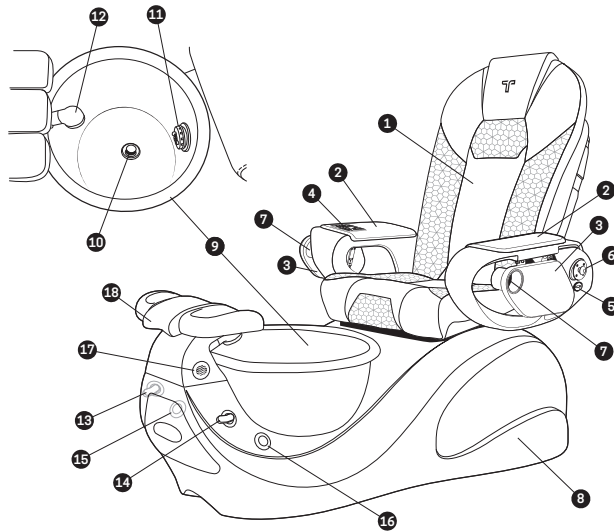
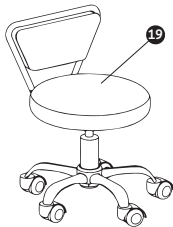

1. Massage chair
2. Flip-up armrest
3. Flip-out manicure tray
4. Built-in remote control
5. USB charger
6. Purse hook
7. Cup holder
8. Fiberglass base
9. Glass basin
10. Push-plug drain

11. Whirlpool jet head
12. Shower head
13. Mixer knob
14. Overflow knob
15. Drain/pump button (optional)
16. Jet button
17. Ventilation inlet (optional)
18. Height adjustable footrest
19. Technician stool



## Vespa / Triumph

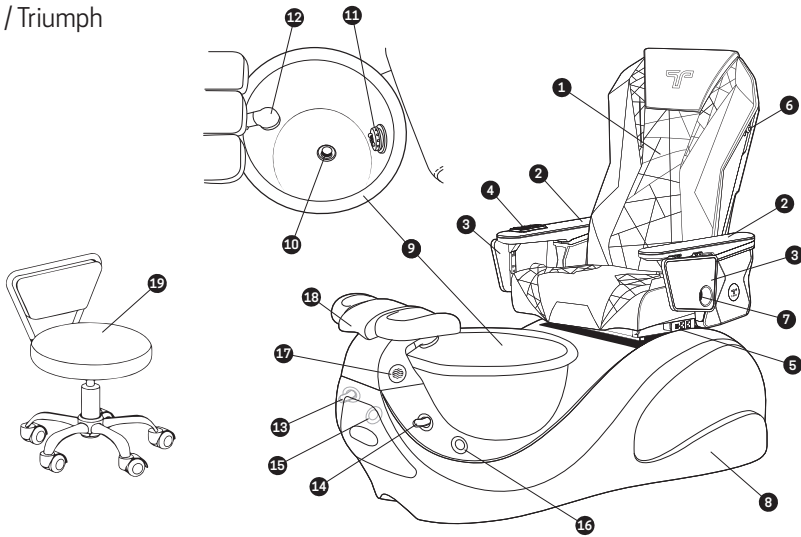

## Vespa / Trident

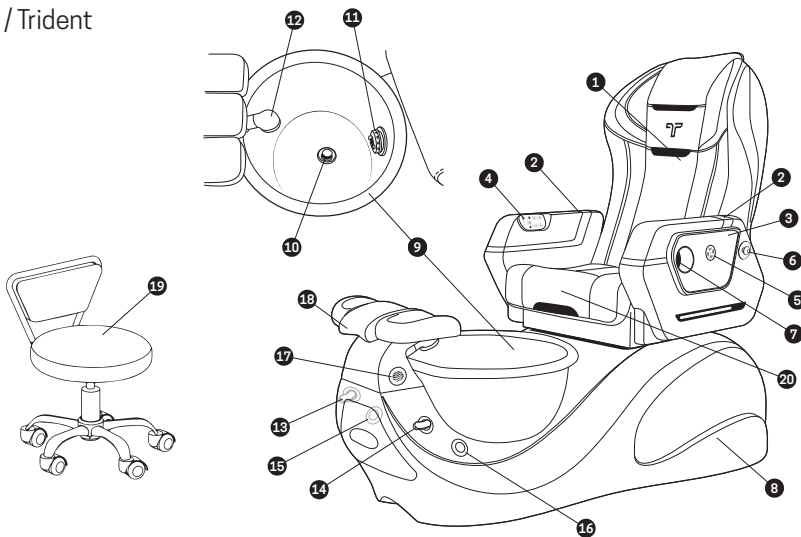

1. Massage chair
2. Armrest: Flip-up (Triumph) / Slidable (Trident)
3. Flip-out manicure tray
4. Built-in remote control
5. USB charging
6. Purse hook
7. Cup holder
8. Fiberglass base
9. Glass basin
10. Push-plug drain

11. Whirlpool jet head
12. Shower head
13. Mixer knob
14. Overflow knob
15. Drain/pump button (optional)
16. Jet button
17. Ventilation inlet (optional)
18. Height adjustable footrest
19. Technician stool
20. Detachable seat cushion (Trident)

# INSTALLATION

## INSTALLATION REQUIREMENTS

Your pedicure spa cannot operate safely or efficiently unless it is provided with adequate electrical power, sufficient water pressure, proper water temperature, and required drainage capabilities.

### Electrical Service

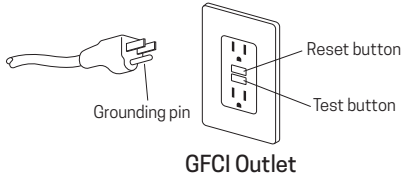

110V, 60Hz, 15Amp GFCI (Ground Fault Circuit Interrupter) protected grounded circuit must be used to supply power to each spa unit, and the main circuit breaker must be at 25Amp. Connect maximum 2 units per each electrical outlet.

If the spa unit were to malfunction or break down, grounding provides a path of least resistance for electrical current to reduce the risk of electric shock, thus reducing the risk of electric shock.

This unit is equipped with a cord having an equipment grounding conductor and a grounding plug. The plug must be plugged into an appropriate outlet that is professionally installed and grounded in accordance with all local codes and ordinances.

If you are in doubt as to whether the spa unit is properly grounded, please check with a qualified electrician. Fatal electric shock and fire could occur with improperly grounded connections. Do not modify the plug provided with the product for any reason; if it will not fit the outlet, have the adequate outlet installed.

### Water Supply

Required water pressure: 30 to 80 psi

Maximum water temperature from the boiler: 150°F (65°C)

### Backflow Protection Device

Some local and state building codes require all pedicure spas installed for commercial usage to have a backflow preventer. If your town / state requires it, the plumber must provide a vacuum breaker at the salon's cost. This device shall be installed between the water inlet hose and the spout.



A licensed plumber / electrician must install the pedicure spa unit conform and comply with local, State and Federal building codes, where applicable.

Failure to comply with applicable regulations will result in the warranty being nullified and void.

Subsequent inspections and approvals that may be required are responsibility of the owner.

Install to permit access for servicing.

### Space requirements

Carefully plan the distribution of your spa units according to the following recommendations.

### Dimensions

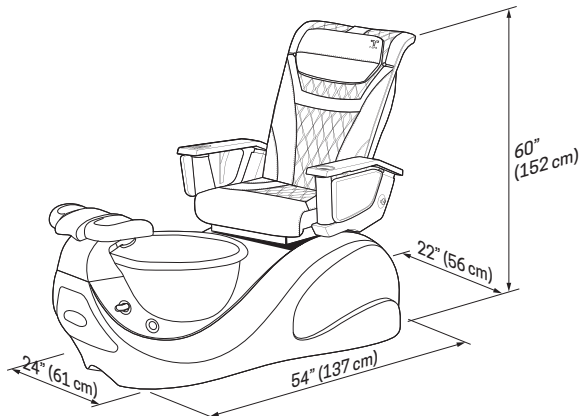

### Wall clearance

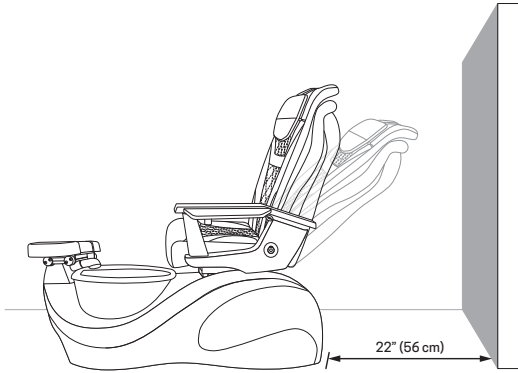

### Safety distance between units

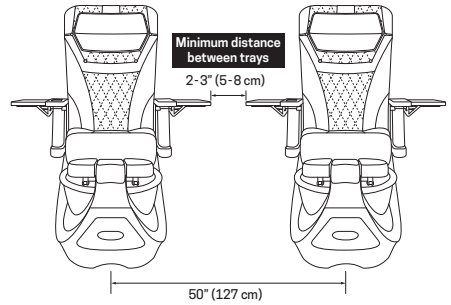

## CAUTION - INSTALL ENSURING AN UNOBSTRUCTED OPERATION OF THE CHAIR

Both the backrest and the seat position are adjustable. When the backrest is at its maximum recline, it must allow 22" (56cm) from back wall to spa chair. This minimum distance ensures an unobstructed recline. Failure to follow this required clearance might damage spa unit components and plumbing connections, which will void your warranty.

### Anchoring of the spa unit to the floor

Each spa base must be anchored securely to the floor. The base may be anchored through the opening in the back of the base wherever access is convenient for the installer.

The floor structure must be level and capable of supporting the spa unit.

Failing to secure your spa unit may result in personal injury or damage to the unit and will void the warranty.

## CHAIR ASSEMBLY TO SPA BASE

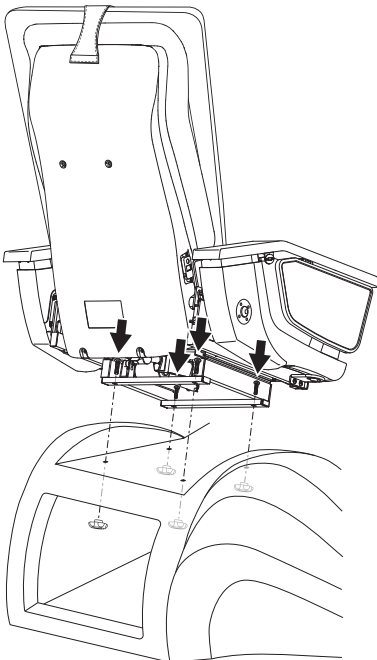

1. Locate the four pre-drilled holes on your pedicure spa base (top) and the four pre-drilled holes on the chair frame (bottom).  
Gently place the chair on top of the base, ensuring that the holes in the base are perfectly aligned with the holes in the chair frame.
2. Insert the screws into the holes in the chair frame and passing through the holes in the spa base.
3. From the rear of the base, reach in through the access opening to attach the nuts to the end of the screws and tighten the nuts with a wrench.  
Your chair is now tightly secured to the spa base.
4. Attach trays to armrest with provided screws.

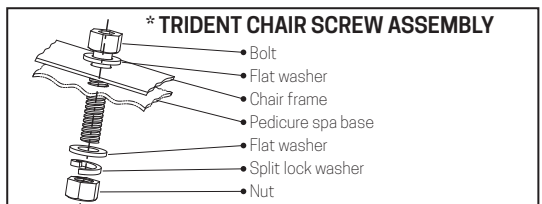

## PLUMBING INSTALLATION

Due to differences in construction layout of salons and city plumbing codes, PVC pipes & elbow connectors are not included. Your certified plumber will need to provide them when doing the installation.

The installation must comply with federal, state, and local building, electrical, and safety codes, where applicable. Installation must be completed by a licensed plumber. Failure to comply with the above may void the warranty.

### Installing at new constructions

Make sure to remove any debris and/or dust from the current hot/cold water pipes before connecting to the new unit. To remove debris, turn on water and drain into a bucket or container.



### Installing replacement spa units

Make sure to use new hot/cold water hoses to replace old ones before installing a new unit. The old debris, rubber, or plastics could clog the water inlet system. Failure to do so will void the warranty.

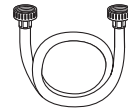

## DRAIN INSTALLATION

### Gravity Sink (Direct Drain) Installation

Connect the spa tub drain to the existing floor sink that leads to the sewage line.

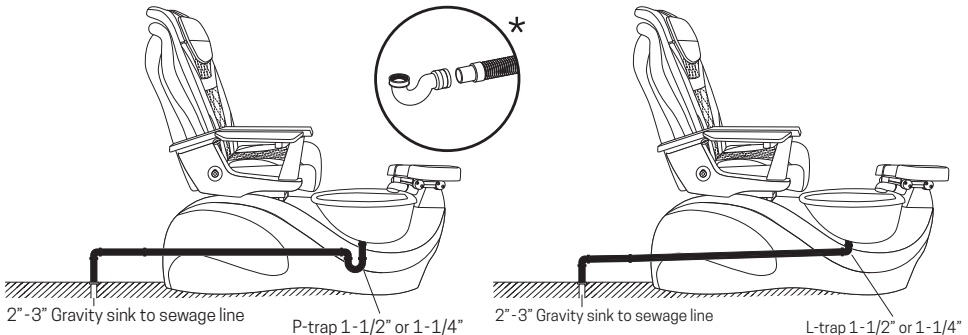

\* Find more about drain pipes and fittings in the Appendix at page 26.

The floor drain should already have a P-Trap and UPC codes.

For gravity drain installations, connecting to a floor sink is recommended. If you need to connect your spa to a wall drain setup, the optional discharge pump system is strongly recommended.

### Discharge pump installation (optional)

Power drain optional upgrade is designed to pump where there is insufficient fall to allow gravity drainage. The discharge pump system connected to an existing wall or floor drain can pump up to 7 ft (2 m) high but, the higher the drain, the lengthier the draining time.

The discharge pump comes factory installed when the spa unit is purchased with this upgrade.

Connect the drainage discharge outlet at the rear of the base to the existing wall or floor drain using a 3/4 inch drain hose.

A Check Valve is required and supplied by the plumber. Pipes, T-connectors, hoses and fittings must be supplied by the plumber as well.

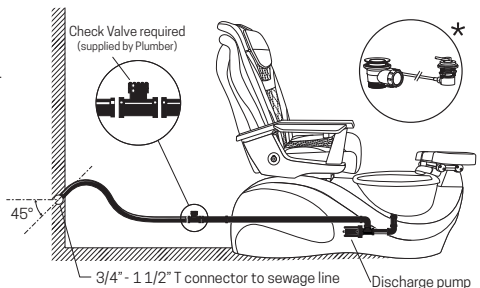

## Drain system recommendation

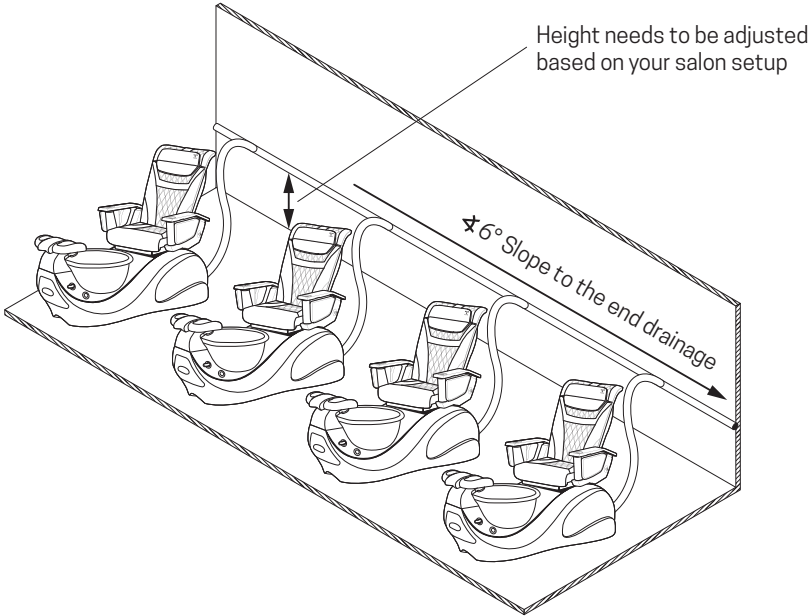

## Water supply installation

Hot and Cold water supply connections are located at the rear of the unit. Please be aware that the Hot/Cold water supply lines are not fitted with optional backflow by default.

**If you need backflow preventers, they are available to include with the spa purchase as optional items.**

1. Carefully connect 3/8" ID hot/cold supply hoses (not provided) to fresh water source,
2. Shut-off valves (not provided) should be installed per plumbing codes. Valves should be placed outside the tub for easy access.

*\* Find more about mixer and shower head in the Appendix at page 27.*

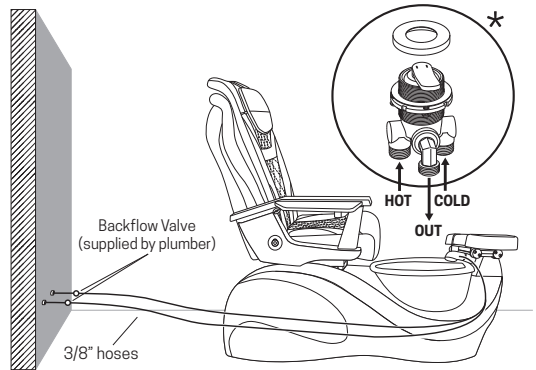

## Ventilation system installation (optional)

The ventilation system comes factory installed inside the base when the spa unit is purchased with this upgrade.

Pull out the stretchable air pipe located inside the spa base and connect to your ventilation system as needed.



Please contact your state department for ventilation requirements and regulations.

## WIRING

Have a qualified licensed electrician install the wiring according to local codes.

The clean jets are 1/18 HP, 120V A.C., 0.55 AMP, 60 Hz.  
GFI protected circuit must be used to supply power to the unit.  
The roller back massage chair uses a 115V A.C. supply.

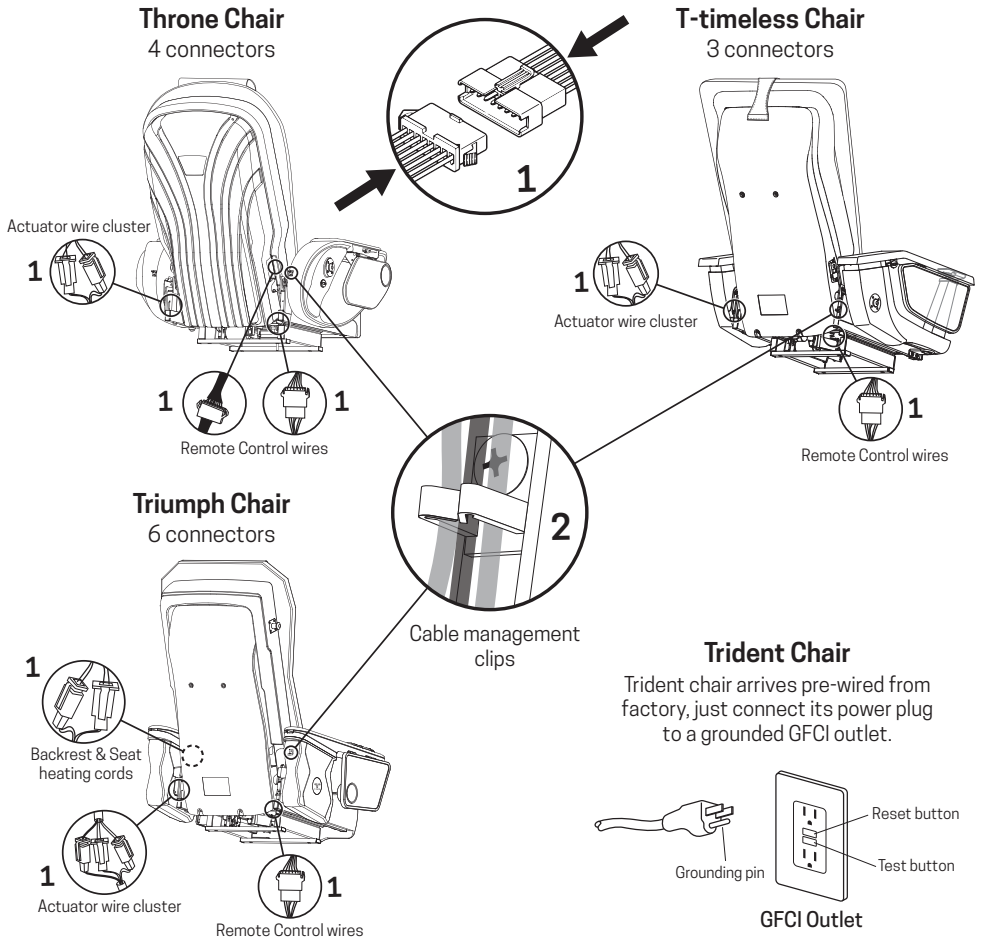

1. Plug all the connectors following the color code and number of pins (2-pin red female connector with 2-pin red male connector, 6-pin black female connector with 6-pin black male connector, and so on).
2. Manage wires using the plastic clip.
3. Connect the power cord to a 110V, 60Hz, 15Amp GFCI wall power outlet. The outlet must be grounded and the main circuit breaker must be at 25Amp. Connect maximum 2 units per each electrical outlet.



### WARNING

DO NOT pull the power cable to disconnect. Always pull the plug from the wall socket.  
DO NOT lay heavy objects on top of the power cord.  
Never use the spa if the power cord is damaged.  
If an electric shock accident would occur, turn off the power immediately and call service.

4. Gently lift up the backrest, making sure that the two side pivots are properly secured to the quick release brackets in the seat frame. Adjust the two side pivots into the quick release brackets if necessary.

5. Before lifting the backrest to the end (straight position), verify that bottom bracket is well hooked onto the pin of the recline actuator. Securely hook the bottom bracket onto the recline actuator pin if necessary.

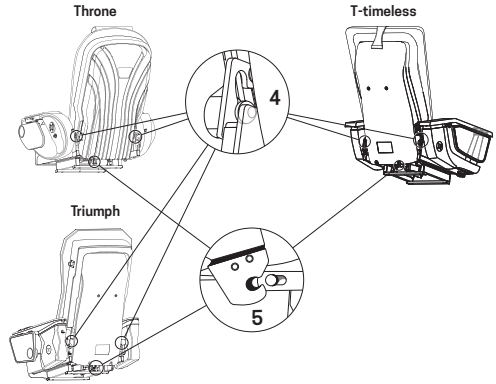

## Trident Chair final assembly steps

### Armrest assembly

1. Push both armrests to the front end, and use the 4 screws M6 × 20 (cross recessed flat round head) and 4 8 elastic washers to lock and fix.
2. Push the handrails to the rear end and use 4 screws M6 × 20 (cross recessed flat round head) and 4 8 elastic washers to lock and fix.

### Backrest assembly

3. Place the rotating shafts on both sides of the backrest into the customized notches on the seat frame.
4. Clip the backrest hook into the pin shaft of the movable electric cylinder of the seat frame, and do not loosen it.

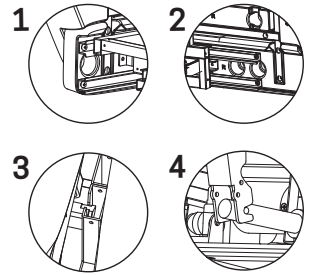

## WHIRLPOOL JET SYSTEM

Every spa unit includes a pipe-less magnetic jet system that provides vigorous foot massages and is very easy to use and sanitize.

### Positioning of jet head on the magnetic terminal

1. Hold Jet Head firmly and bring it closer to the round Magnetic Terminal inside the tub, being careful not to release it prematurely to prevent an impact between the Jet Head and the Magnetic Terminal.

#### CAUTION!

Carelessly releasing the Jet Head and letting it impact with the Magnetic Terminal can shorten the life expectancy of components.

2. When the Jet Head is near the Magnetic Terminal, place the Jet Head onto the four-dimple area.

**NOTE:** Liners can be used on a magnetic jet system. The liner must sit between the Magnetic Terminal and the Jet Head assembly.

## TESTING AFTER INSTALLATION

Once the spa unit is fully installed, run the following check-up.

1. Fill tub with water just above the jets. Carefully check for leaks at the drain and motor mount.
2. After checking underneath for leaks, turn on the whirlpool system by pushing the Jet Button and watch for leaks as water circulates.
3. Let the tub run on full cycle.
4. Push open the drain plug to discharge and check for any leaks in the drain setup.

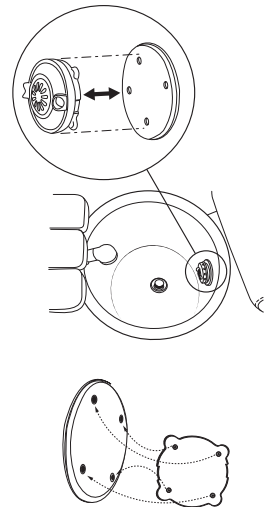

# PEDICURE SPA OPERATION

## WARNING: THERMAL RESETTING PROTECTION DEVICE

The massage chair is equipped with a thermal resetting protection device. This is a safety feature to protect it from overheating. If the chair should suddenly stop and will not start, turn the main power switch off, and do not operate the chair for at least 30 minutes. Failure to turn the chair off may result in the chair starting unexpectedly when the device cools.

## SWITCHING ON THE PEDICURE SPA

1. Push the switch located on the back of the chair to its ON position.
2. Press ON in the remote control located on the right-side chair armrest.

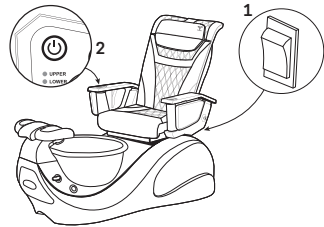

## FILLING THE BASIN

1. Screw in place the push plug into the drain. Push closed the drain plug.
2. Lift the single lever hot/cold mixer faucet to fill the basin. Fill the basin until the Jet System is completely submerged in water, with a water level at least 1 inch over the Jet.
- If the water level decreases during the operation of the whirlpool, please add more water.
3. Lift the single lever hot/cold mixer faucet to fill the basin. Fill the basin until the Jet System is completely submerged in water, with a water level at least 1 inch over the Jet.
4. If the water level decreases during the operation of the whirlpool, please add more water.

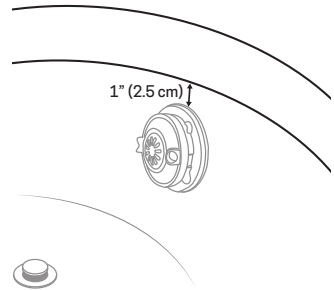

**DO NOT RUN DRY. BASIN MUST FILLED WITH WATER TO LEVEL INDICATOR.  
DO NOT USE FOAMING, SUDSING, OR MINERAL OIL BASED ADDITIVES IN THE WATER.**

## AUTO FILL (OPTIONAL UPGRADE)

1. Switch the pedicure spa. Make sure that the mixer is set to an adequate temperature.
  2. Press the Auto Fill button. The basin will automatically fill and turn off when adequate water level is detected by the sensor. The magnetic jet will start automatically.
  3. To stop water any moment of the cycle, press Auto Fill again.
- If you want to add more water to the basin, use the mixer.

## STARTING WHIRLPOOL



**CAUTION**

Make sure that the Jet Head is well attached to the Magnetic Terminal, and that the water level is at least 1 inch (2.5 cm) over the Whirlpool Jet.

NEVER run without magnet jet head being fully submerged in water. Doing so, even for a short time, will result in damage to the head.

1. Turn on by pressing the Jet Button to start the whirlpool function.
2. To stop the whirlpool function, press the Jet Button again.

**Always ensure that the jet motor is off when not in use.**



## DRAINING THE BASIN

Push open the drain plug. If the spa has a gravity drain system installed, the basin will empty at a speed determined by the waste-water plumbing.

If the optional discharge pump system is installed, press the Drain/Discharge Pump button to activate the discharge pump motor. The average drain time is approximately one minute (depending on plumbing characteristics).



### WARNING

Do not try to remove the push plug while it is closed. Attempting to remove the drain plug while in its closed position does not usually work, and there is a good chance that the drain lid could be scratched in the process.

DO NOT turn on the drain pump unless there is a significant amount of water in the basin. THE WARRANTY WILL BE VOID IF THE PUMP HAS BEEN RUNNING DRY.

## ADJUSTING FOOTREST HEIGHT

There are two locking positions on each footrest.

To adjust footrest height, pull it up until its upper position, or push back down to its lower position.

Be careful of pinch points when adjusting, and always ensure the footrest is adequately locked into place.

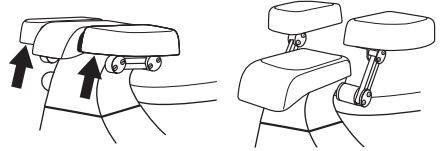

## REMOTE CONTROL OPERATION

Use the remote control located on the right-side chair armrest to calibrate the chair, adjust chair distance to the pedicure basin, adjust backrest inclination, and set up a massage session.

### T-TIMELESS CHAIR REMOTE CONTROL

#### POWER

1. Turns Spa ON to Stand By mode until a function is introduced.
2. Spa will auto shut-down if no functions are introduced for 150 seconds.

#### RESTORE

1. Turn power ON shut off all functions
  2. Press RESTORE
- This will block all other buttons while the restoring process completes (14 seconds)

#### RECLINE BACKREST

Press to bring backrest backwards or forwards until reaching the preferred angle

#### BACK MASSAGE

Set up back massage  
**UPPER** Shoulder area  
**LOWER** Waist area  
**UPPER + LOWER** Full back  
**OFF** Stand by

#### WHEEL

Press to adjust massage wheels up or down until the desired position

#### RANGE

Set back massage vertical range  
**FULL / PART / SPOT**

#### MASSAGE INTENSITY

Set intensity  
**HARD / MED / SOFT**

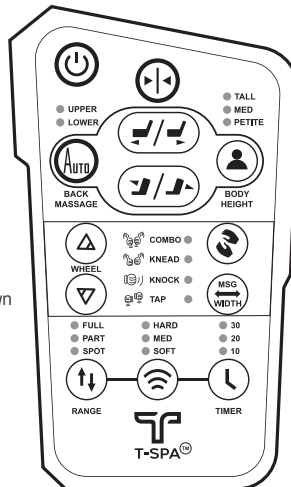

#### CHAIR POSITION

Press to move chair backwards or forwards until reaching the adequate position

#### BODY HEIGHT

Set user height  
**TALL / MED / PETITE**

#### MESSAGE OPTIONS

-  COMBO
-  KNEAD
-  KNOCK
-  TAP

#### MSG WIDTH

Press until reaching the desired  
**TAP / KNOCK** width

#### TIMER / MANUAL

Set to manual or set up a timer  
**10 / 20 / 30** minutes

#### TIPS: SHIATSU

1. Press **TIMER** to set time
2. Press **RANGE** to select **FULL** or **PART**
3. Press **WIDTH** to fine tune comfort

## THRONE CHAIR REMOTE CONTROL

### POWER

1. Turns Spa ON to Stand By mode until a function is introduced.
2. Spa will auto shut-down if no functions are introduced for 150 seconds.

### RECLINE BACKREST

Press to bring backrest backwards or forwards until reaching the preferred angle

### BACK MASSAGE

- Set up back massage  
**UPPER** Shoulder area  
**LOWER** Waist area  
**UPPER + LOWER** Full back  
**OFF** Stand by

### WHEEL

Press to adjust massage wheels up or down until the desired position

### RANGE

Set back massage vertical range  
**FULL** / **PART** / **SPOT**

### MASSAGE INTENSITY

Set intensity: **HARD** / **MED** / **SOFT**

### RESTORE

Press and hold for 1.5 seconds, this will reset all set-ups.  
 The light indicator will blink until the restoration process completes (24 seconds).  
 To stop the at any moment process, press 

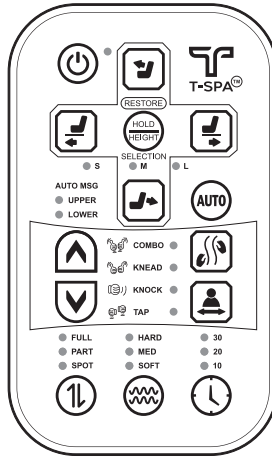

### CHAIR POSITION

Press to move chair backwards or forwards until reaching the adequate position

### BODY HEIGHT

Set user height  
**S** / **M** / **L**

### MESSAGE OPTIONS

-  COMBO
-  KNEAD
-  KNOCK
-  TAP

### MSG WIDTH

Press until reaching the desired  
**TAP** / **KNOCK** width

### TIMER / MANUAL

Set up a timer: **10** / **20** / **30** minutes

## TRIUMPH CHAIR REMOTE CONTROL

### POWER

1. Turns Spa ON to Stand By mode until a function is introduced.
2. Spa will auto shut-down if no functions are introduced for 150 seconds.

### RECLINE BACKREST

Press to bring backrest backwards or forwards until reaching the preferred angle

### AUTOMATIC MASSAGE

- UPPER** Shoulder area  
**LOWER** Waist area  
**UPPER + LOWER** Full back  
**OFF** Stand by

### WHEEL

Press to adjust massage wheels up or down until the desired position

### RANGE

Set back massage vertical range  
**FULL** / **PARTIAL** / **SPOT**

### MASSAGE INTENSITY

- SOFT**   
**MED**   
**HARD** 

### HEAT

- SOFT**   
**MED** 

### RESTORE

Press and hold for 1.5 seconds, this will reset all set-ups.  
 The light indicator will blink until the restoration process completes (24 seconds).  
 To stop the at any moment process, press 

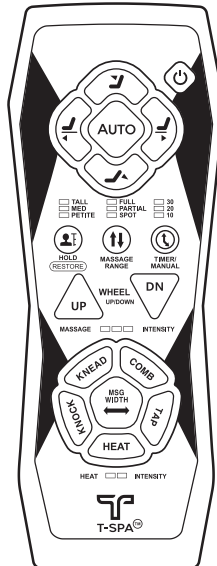

### CHAIR POSITION

Press to move chair backwards or forwards until reaching the adequate position

### BODY HEIGHT

Set user height  
**TALL** / **MED** / **PETITE**

### MESSAGE OPTIONS

-  COMBO
-  KNEAD
-  KNOCK\*
-  TAP

\* **KNOCK**: Impulse tapping massage, 2 intensity levels available

### MSG WIDTH

Press until reaching the desired  
**TAP** / **KNOCK** width

### TIMER / MANUAL

Set up a timer: **10** / **20** / **30** minutes

## TRIDENT CHAIR REMOTE CONTROL

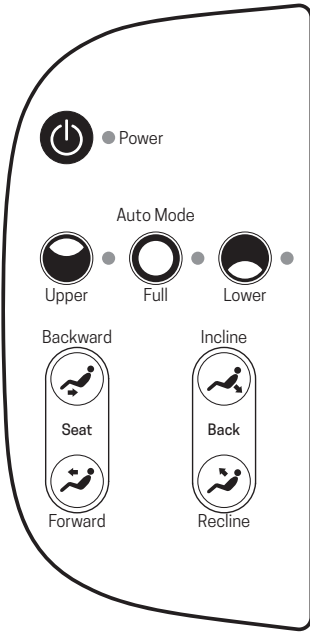

### POWER

Start or stop massage

### UPPER BACK

The massage device mainly covers the neck and shoulder area

### FULL BACK

The massage device works with various techniques at different body areas of the upper body

### LOWER BACK

The massage device mainly covers the back and waist area

### CHAIR POSITION

Press and hold to move the chair backwards or forwards until reaching the adequate position

### RECLINE BACKREST

Press to bring backrest backwards or forwards until reaching the preferred angle



### WARNING

#### PREVENT ACCIDENTS AND/OR INJURIES

Please follow the safety recommendations for using the spa found on page 4. DO NOT massage on the same spot for over 5 minutes.

When massaging over 30 min, make sure to take at least a 10-min brake between massages.

It is strongly recommended to drink a glass of water after a massage session, as this helps improve circulation.

## TECHNICIAN CONTROLLER

Use the technician controller to adjust chair distance to the pedicure basin and set backrest inclination.

Decrease backrest inclination

Move the chair forward,  
closer to the pedicure basin



Move the chair backwards,  
away from the pedicure basin

Increase backrest inclination

## MANICURE TABLE

The manicure table can be swiveled and turned around the chair to the most comfortable position. It can be also used as an esthetician working table.

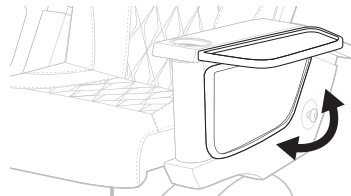

## CLEANING AND MAINTENANCE

The following procedures are important guidelines that will help keep your spa unit clean and in good condition for years to come. It is extremely important to clean and disinfect every unit after each client and after the last pedicure of the day.

### YOU ARE REQUIRED TO CHECK WITH YOUR STATE BOARD FOR MANDATORY CLEANING AND DISINFECTING REQUIREMENTS AND PROCEDURES.

For the safety of your clients, always use the regulations as a minimum standard for cleaning and disinfecting. Combining your state standards with the regimen listed below will provide your clients with a safe and healthy pedicure spa environment experience.

#### Safety Requirements for Pedicure Spas

The Bureau of Barbering and Cosmetology requires that salons using whirlpool pedicure foot spas must follow these disinfecting procedures to ensure proper cleaning and maintenance of the equipment and prevent bacterial or parasitic spread disease.

Violation of this section may result in an administrative fine and/or disciplinary action. Each foot spa that is not in compliance with this section may result in a separate violation.

*Authority cited: Section 7312, Business and Profession Code. Reference: Section 7312 (e), Business and Profession Code.*

Cleaning or sanitizing is NOT disinfecting. According to the Centers for Disease Control and Prevention (CDC), and the US Environmental Protection Agency (EPA), disinfecting occurs only when there is a reduction of pathogenic microbes at 99.999%. Sanitizing is only a reduction of 99.9%. Cleaning of whirlpool pedicure spa requires surfactant and chelating detergents that are low-foaming and can remove body oils, organic oil additives, mineral oil, skin cells, nail clippings etc. that can accumulate both in the basin and the jets which may become a fertile area for micro-organism to grow.

### Selecting appropriate cleaning products and procedures



#### CAUTION

DO NOT USE acetone, paint thinner, bleach, "Armor All" type cleaners, or industrial cleaners for ANY part of your chair, basin, or components.

DO NOT USE powdered cleansers or abrasives. A clean towel or sponge are all you need.

DO NOT place nail care products on the basin.

Extended exposure to chemicals like bleach can damage the basin, footpad, and upholstery.

The use of oil-based products can build up in the whirlpool system, causing clogging in the jets. Adherence to the above cleaning will minimize build up. T-SPA DO NOT recommend the use of mineral oil-based products.

Failure to comply with all cleaning instructions can cause damage and void your warranty.

No internal cleaning of the spa components is necessary.

Category	Care / Maintenance Recommendation
Spa base surface	Wipe dry any water that may splash onto surfaces.
Most Dirt & Residue	Use soapy water, ammonia based cleaner, (not window cleaner) rinse and wipe completely dry. Commercially available solid surface cleaners will also work well.
Prevent Hard Water Marks	Rinse and wipe completely dry after cleaning.
Remove Hard Water Marks	Use cleaner formulated for removing hard water marks, such as CLR or Lime-A-Way.
Upholstery	Use a mild soap and water solution and gently clean any dirt or grime that may appear. DO NOT over wet. DO NOT use strong solvents, grease solutions, nor washing powder.
Whirlpool jet system	Remove and disassemble the jet head following the instructions.
Water basin	Use EPA-registered cleansers and disinfectants with bacterial, fungicidal and virucidal activity. Wipe dry with a clean towel. Use small amounts of alcohol to remove stains. DO NOT use abrasives, acetone, concentrate chlorine, nor any other harmful chemicals.

## A special note pertaining to bleach

While bleach seems to be used extensively for cleaning and disinfecting of pedicure chair basins, it is NOT recommended nor is it effective. Moreover, excessive use of bleach may greatly reduce the longevity of your pedicure chair internal components (i.e. pumps, jet assembly, etc.). Excessive and repeated use of bleach may also void your warranty. As always, you are required to check with your state board for mandatory cleaning and disinfecting requirements and procedures.

## CLEANING ROUTINE

Always clean after each client session and at the end of the day following the below procedure.

### After each customer

1. All water shall be drained and all debris shall be removed from the spa tub.
2. The spa tub must be cleaned with soap or detergent and water.
3. The spa tub must be disinfected with an EPA-registered disinfectant with demonstrated bactericidal, fungicidal, and virucidal activity, which must be used according to the manufacturer's instructions.
4. The spa basin must be wiped dry with a clean towel.

### At the end of each day

1. Fill the tub with warm water and add the correct amount of an EPA-registered liquid disinfectant.
2. Turn on the jets to circulate the water for at least 15 minutes, scrubbing all visible residue from the inside walls of the basin with a sponge/soft brush.
3. Drain the basin, rinse with fresh water, and wipe dry with a clean towel.
4. Follow the magnetic jet cleaning procedure explained below.

**NOTE 1:** Brushes must be cleaned / disinfected after each use. Rinse with clean fresh water and drain.

**NOTE 2:** The use of oil-based products can build up in the jet system and build up onto the surface of the basin. Daily cleaning will minimize build up.

## MAGNETIC JET CLEANING



THE MAGNETIC JET MUST BE CLEANED BETWEEN EVERY CLIENT.  
Do not remove Jet Head until motor is fully stopped.

### Removal and cleaning of Jet Head

1. Remove Jet Head by gently pulling it away from the Magnetic Terminal.
1. Twist off Jet Head Cover counter-clockwise and remove Impeller from the Jet Housing.
2. Spray Jet Cover, Impeller and Jet Housing with disinfectant. Scrub clean each part using a sponge or a soft brush with soapy water to remove visible residue.
3. Wipe dry with a clean towel.

### Re-installation of Jet Head

1. Reassemble all Jet Head components as they were before removal.
2. Snap the Jet Head back onto the Magnetic Terminal inside the tub.

### Discharge Pump (optional) Valve Cleaning

If your spa unit is equipped with a discharge pump, its check valve will need to be cleaned periodically.

Slowly twist open check valve, note position of the spring/plunger. Clean out check valve.

Place spring/plunger in original location and twist close.

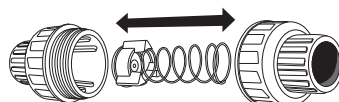
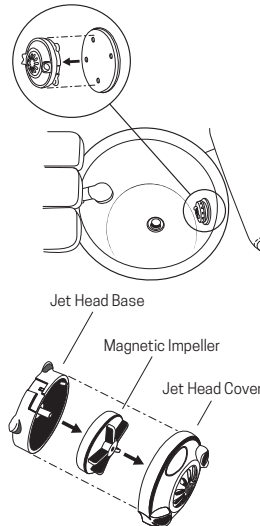

# TROUBLESHOOTING

This helpful troubleshooting guide will provide you with information about how to recognize a problem with your product, determine possible causes, and find a solution.

In the event your specific situation is not covered in this guide, please contact our technical support department to assist you.

Beyond the troubleshooting guide below, do not attempt to repair the issue yourself. This can void your warranty. Unauthorized service will not be covered.

Please be sure to contact Continuum Customer Service first at (888) 508-8772 or reach us via e-mail at [info@tspallc.com](mailto:info@tspallc.com)

Issue	Solution
Power problem / Spa unit not turning on	<ol style="list-style-type: none"><li>1. Ensure the power cord is properly plugged into an operational GFCI power supply/outlet.</li><li>2. Check GFCI reset and circuit breakers or fuses.</li><li>3. Ensure the outlet in your room is receiving power. This can be done by plugging in a small appliance and turning it on.</li></ol>
Power problem / Jet not turning on	<ol style="list-style-type: none"><li>1. Ensure the power cord is properly plugged into an operational GFCI outlet.</li><li>2. Check GFCI reset and circuit breakers or fuses.</li><li>3. Ensure impeller is correctly installed in housing.</li><li>4. Reset the motors by unplugging the system, waiting 5 seconds and then plugging in again.</li></ol>
Excessive Noise from Jets	<ol style="list-style-type: none"><li>1. Remove jet assembly and inspect for dirt build-up, debris, or damage.</li><li>2. Follow cleaning instructions or replace if necessary.</li></ol>
Water Leakage	<ol style="list-style-type: none"><li>1. Check and ensure all visible bolts are tightened.</li><li>2. Call a plumber to determine the source of the leak. If the leak is from the jet system, contact customer service.</li></ol>
Chair suddenly stopped and will not start again	The thermal resetting protection device might have activated, this is a safety feature to protect it from overheating. Turn the main power switch off, and do not operate the chair for at least 30 minutes. Failure to turn the chair off may result in the chair starting unexpectedly when the device cools.

# LIMITED WARRANTY

T-SPA designs and assembles pedicure spas to the highest quality standards. Accordingly, T-SPA guarantees to the original owner that this product leaves the factory free from defects related to materials and manufacturing. If for any reason a failure related to materials and manufacturing were to occur, check the Standard Warranty period list below to know the time periods for the different components.

Limited warranty term commences on date product is received by the original owner. The shipping date and the uniquely coded Serial Number on the back of each spa chair marks the starting point of the warranty.

The warranty is null and void if the pedicure spa has been removed from its initial place of installation, or if it was not installed in accordance with federal, state, or local codes and ordinances.

This warranty shall be voided if the product has been modified, tampered with, misused, or subjected to abnormal working conditions, incorrect installation or maintenance, negligence, or inadequate cleaning practices. This warranty does not cover physical damage to the product surface.

This warranty does not apply when the malfunction results from the use of this product in conjunction with accessories, other products, or peripheral equipment not designed by T-SPA.

The original owner is responsible for all labor and shipping charges necessary to replace or repair the pedicure spa. T-SPA will not be liable for any consequential, incidental, or contingent damages.

This limited warranty is for the original owner and not transferable.

## STANDARD WARRANTY

1. Limited Two (2) years Parts and Labor for the fiberglass on the spa shell.
2. Limited One (1) year Parts and Labor for the Gel on the spa shell.
3. Limited One (1) year Parts for the paint on the spa shell.
4. Limited One (1) year Parts for the resin sink and fiberglass sink.
5. Limited warranty based on shipment for the glass sink.
6. Limited One (1) year Parts for hydraulic system and electrical components.
7. Limited One (1) year Parts and Labor for the Whirlpool Pump, Clean Jet and Magnetic Jet.

This limited warranty shall be in full effect for original owners of the product experiencing damages related to workmanship, mechanical, installation, or composition failures, so long as the purchased goods are correctly installed and used in accordance with official installation and maintenance instructions.

## WARRANTY EXCLUSIONS

The following are examples of what is not covered by the warranty:

1. Damage to pump parts and/or motor parts due to obstruction in plumbing lines.
2. Staining, fading or discoloration of plastic surfaces due to exposure and/or the use of harmful cleaning agents or chemicals.
3. Natural wear and tear including but not limited to staining, fading, or discoloration of upholsteries, armrests, or footrest.
4. Fading, discoloration or staining of basin or any surface area of the pedicure spa caused by water additive or improper water treatment (such as calcium built up) are not covered by this warranty.
5. Freight damage, misuse, neglect, accident, abuse, and natural disaster.
6. Unauthorized repairs and/or modification or tampered in any way.
7. Damage resulting from standing in the basin.
8. Damage or malfunction due to improper installation including but not limited to, failure to comply with all national, state and local plumbing, electrical and building codes.
9. Natural wear and tear of remote control including broken buttons, cracked screens, or water damage.
10. Drain pump damage due to residue built up in drain pipe and/or due to the lack of maintenance.

## SERVICE

Should service be required for defect or malfunction during the warranty period, please contact us.

1. The dealer shall forward all warranty-related matters to our Customer Service Department.
2. Serial Numbers and Original Invoice must accompany all warranty claims.
3. Customers are responsible for shipping defective parts back to T-SPA. These parts must be packaged correctly to protect against any further damage.
4. All parts are to be shipped by Ground services, average of 2-5 days.
5. All defective parts must be shipped back to T-SPA within 30 days of receiving the new replacement parts or warranty will be void.
6. Any warranty claim that cannot be determined over the phone call, the customer must send photos to T-SPA for inspection related.
7. Any service performed on the product without T-SPA authorization will also void the warranty.
8. Each Service call from the customer will be assigned a Claim Number. The Claim Number will stay open until the problem is resolved.

## Parts for which labor / service is NOT COVERED

The following components are simple to replace and DO NOT require a service technician. Therefore, though the part is covered under the guidelines of the warranty agreement.

1. Jet cover, impeller and / or jet assembly.
2. Faucet cartridge, shower head.
3. Footrest.
4. ON/OFF air actuated button.
5. Drain Plug
6. Remote control
7. Water tub
8. Replacement upholstery
9. Manicure trays

During the Limited Warranty period, T-SPA will, at its sole discretion, repair or replace any defective component. All component parts removed under this Limited Warranty become property of T-SPA.

And all replacement component/s MUST be return to T-SPA within 30 days of replacement. If not, replaced component/s will be charge as its cost/s.

## LIMITATION OF LIABILITY

By using the pedicure spa chairs, owner agrees that the obligation of T-SPA shall not extend to indirect or consequential damage or injury which may result from pedicure spa use.

Owner agrees that the obligations of T-SPA are limited to those set herein and that there are no other obligations except those expressly agreed to in writing by T-SPA.

To the extent allowed by local law, except for the obligations specifically set forth in this warranty statement, in no event will empress or its third party suppliers be liable for any damaged caused by empress pedicure spa or the failure of empress pedicure spa including any lost profit or savings, business interruption, loss of use or any other commercial or economic loss of any kind, or special, incremental, or consequential damages. This limitation of liability applies whether damages are sought, or a claim made, under this limited warranty or as a tort claim, a contract claim or any other claim.

No dealer or other person has any authority to bind T-SPA to changes or additions to this warranty or its products. Accordingly, T-SPA is not responsible for such warranties or representations.



# LIMITED WARRANTY REGISTRATION FORM

## IMPORTANT

To validate the limited warranty, Limited Warranty Registration Form MUST be filled out completely and return to T-SPA within 30 days of original purchased date. This Limited Warranty is valid if T-SPA received the registration form from the original purchaser.

FULL NAME: \_\_\_\_\_

EMAIL ADDRESS: \_\_\_\_\_

SALON NAME: \_\_\_\_\_

SALON ADDRESS: \_\_\_\_\_

SECOND ADDRESS (Suite, Unit): \_\_\_\_\_

CITY: \_\_\_\_\_ STATE: \_\_\_\_\_ ZIP CODE: \_\_\_\_\_

DISTRIBUTOR (if any): \_\_\_\_\_

DISTRIBUTOR ADDRESS: \_\_\_\_\_

CITY: \_\_\_\_\_ STATE: \_\_\_\_\_ ZIP CODE: \_\_\_\_\_

VERSION: T- \_\_\_\_\_ MODEL: \_\_\_\_\_ Spa Pedicure Chair

INVOICE NO.: \_\_\_\_\_

DATE OF PURCHASE: \_\_\_\_\_

### Completed Warranty Registration Form to:

**T-SPA MFG, LLC**  
10510 KINGHURST  
HOUSTON, TX 77099  
FAX: (832) 230-5486  
EMAIL: info@tspallc.com

# APPENDIX

## Drain pipes and fittings

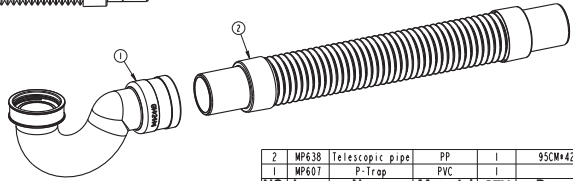
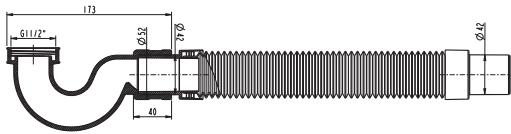

2	MP638	Telescopic pipe	PP	1	95CM*42*42
1	MP607	P-Trap	PVC	1	
NO.	Item	Name	Material	QTY	Remarks

## Drain and Overflow

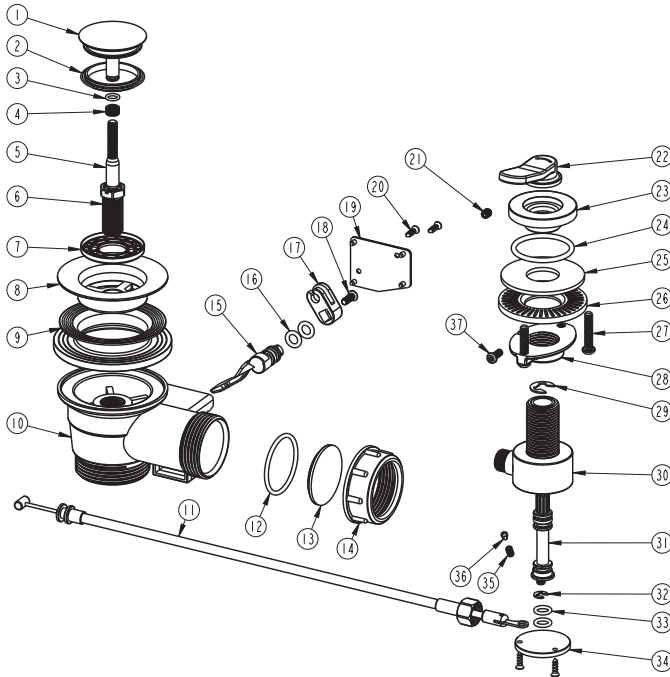

37	7009	Screw	304#	1	
36	8221	dowel	POW	1	
35	8222	spring	304#	1	
34	8139	cover	PP	1	
32	1282	O-Ring	NGR	2	
32	8144	ring	304#	1	
31	0043	Switch shaft	ZINC	1	
30	8138B	assembly	ABS	1	
29	8143	ring	304#	1	
28	7102	nut	ZINC	1	
27	M5X30	Screw	304#	2	
26	7118	gasket	ZINC	1	
25	8174	gasket	NGR	1	
24	40X3	O-Ring	NGR	1	
23	1040	trim	BRASS	1	
22	4105	Handle	ZINC	1	
21	M5X6	Screw	304#	1	
20	M3X14	Screw	304#	4	
19	8098	cover	PP	1	
18	7132	Screw	201#	1	
17	3153	connector	ZINC	1	
16	11X25	O-Ring	NGR	2	
15	3152	connector	BRASS	1	
14	Z1023	G1/2 nut	PP	1	
13	Z1028	gasket	PP	1	
12	40X25	O-Ring	NGR	1	
11	81417	assembly	BRASS	1	
10	H1019	assembly	pp	1	
9	8036	gasket	SILYS	1	
8	5027	main body	BRASS	1	
7	8133	filler	PP	1	
6	7049	Screw	BRASS	1	
5	7050	M6 Screw	304#	1	
4	7034	nut	BRASS	1	
3	63X15	OR#	7#	1	
2	8037	O-Ring	NGR	1	
1	7032	cover	BRASS	1	
NO.	Item	Name	Material	QTY	

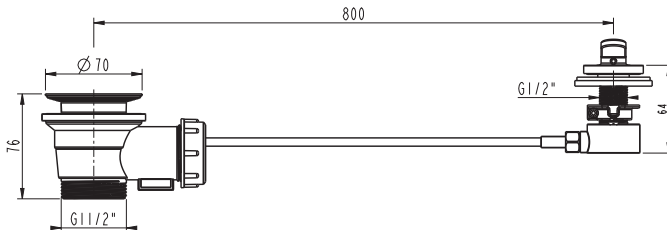

# Mixer

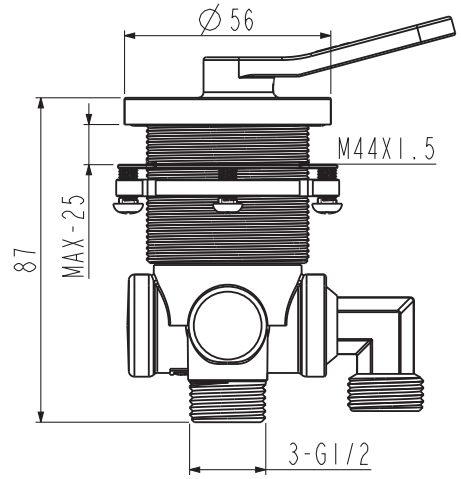
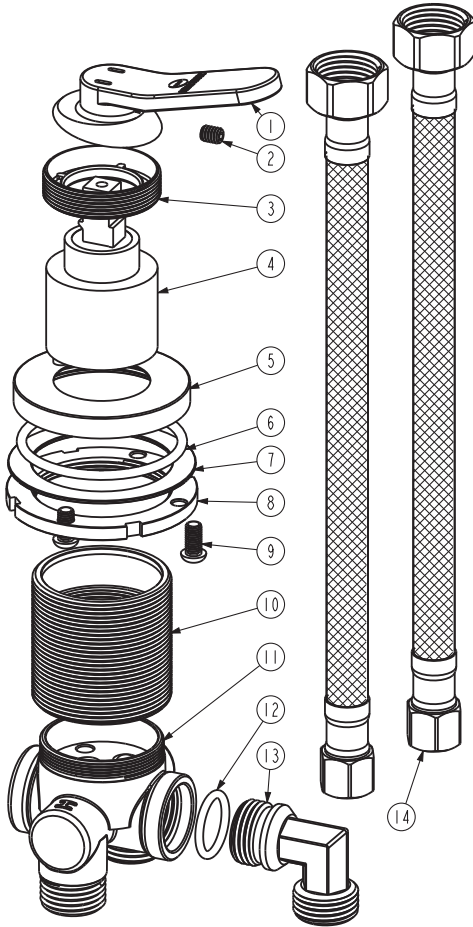

14	12907	Flexible hose	304#	2
13	3124	elbow	BRASS	1
12	21X25	O-ring	NBR	1
11	2151	Body	BRASS	1
10	7108	The sleeve	BRASS	1
9	7003	Screw	201#	4
8	7007	nut	BRASS	1
7	3005	gasket	304#	1
6	53X3	O-ring	NBR	1
5	1056	Plate	BRASS	1
4	0003	35 idle valve combination		1
3	7107	nut	304#	1
2	M5X7	Screw	304#	1
1	4106	Handle	ZINC	1
NO.	Item	Name	Material	QTY

# Shower head

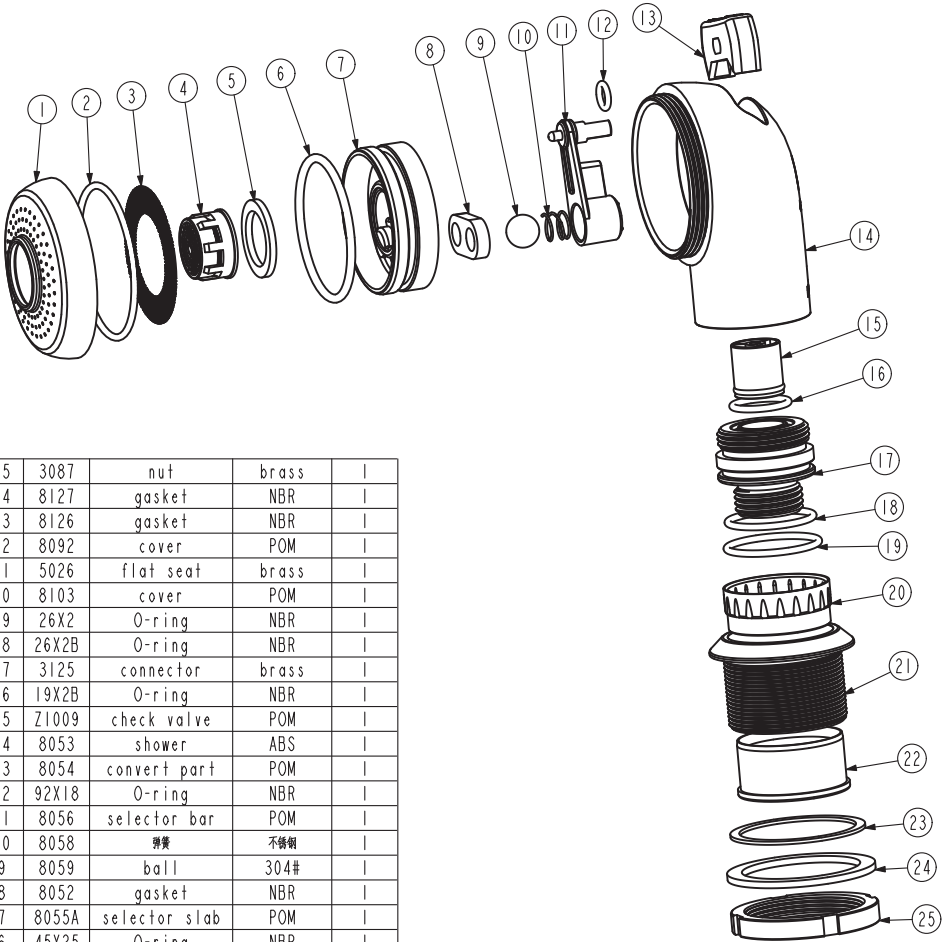

25	3087	nut	brass	1
24	8127	gasket	NBR	1
23	8126	gasket	NBR	1
22	8092	cover	POM	1
21	5026	flat seat	brass	1
20	8103	cover	POM	1
19	26X2	O-ring	NBR	1
18	26X2B	O-ring	NBR	1
17	3125	connector	brass	1
16	19X2B	O-ring	NBR	1
15	Z1009	check valve	POM	1
14	8053	shower	ABS	1
13	8054	convert part	POM	1
12	92X18	O-ring	NBR	1
11	8056	selector bar	POM	1
10	8058	弹簧	不锈钢	1
9	8059	ball	304#	1
8	8052	gasket	NBR	1
7	8055A	selector slab	POM	1
6	45X25	O-ring	NBR	1
5	8051	gasket	NBR	1
4	6016B	The gas bubble	ABS	1
3	8071	meshes	304#	1
2	48X2	O-ring	NBR	1
1	8072A	outlet cover	POM	1
<b>NO.</b>	<b>Item</b>	<b>Name</b>	<b>Material</b>	<b>QTY</b>

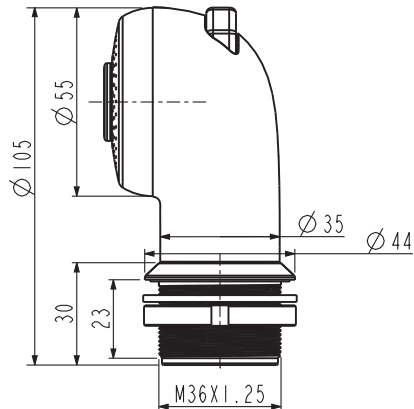

# IAPMO RESEARCH AND TESTING, INC.

5001 E. Philadelphia Street, Ontario, CA 91761 • Phone (909) 472-4100 • Fax (909) 472-4244 • www.iapmort.org



## CERTIFICATE OF LISTING



IAPMO Research and Testing, Inc. is a product certification body which tests and inspects samples taken from the supplier's stock or from the market or a combination of both to verify compliance to the requirements of applicable codes and standards. This activity is coupled with periodic surveillance of the supplier's factory and warehouses as well as the assessment of the supplier's Quality Assurance System. This listing is subject to the conditions set forth in the characteristics below and is not to be construed as any recommendation, assurance or guarantee by IAPMO Research and Testing, Inc. of the product acceptance by Authorities Having Jurisdiction.

*Issued To:*

### QIANG YING HOSE FACTORY

BLOCK 1, NO. 225 JIAXING RORTH ROAD, SHUIKOU TOWN, KAIPING , GUANGDONG, CHINA

*Product:*

### Flexible Water Connectors

*Products are in compliance with the following code(s):*

**Uniform Plumbing Code (UPC®)**  
**National Plumbing Code of Canada**

*Products are in compliance with the following standard(s)*

**ASME A112.18.6-2017/CSA B125.6-17**

File Number: 12907

Effective Date: April 2021

Void After: April 2026\*

  
Chairman, Product Certification Committee



  
Chief Technical Service Officer

\*This certificate is not evidence of current listing. To verify listing status, visit the IAPMO R&T Product Listing Directory at [pld.iapmo.org](http://pld.iapmo.org)

This listing period is based upon the last date of the month indicated on the Effective Date and Void After Date shown above. Any change in material, manufacturing process, marking or design without having first obtained the approval of the Product Certification Committee, or any evidence of non-compliance with applicable codes and standards or of inferior workmanship, may be deemed sufficient cause for revocation of this listing. Production of or reference to this form for advertising purposes may be made only by specific written permission of IAPMO Research and Testing, Inc. Any alteration of this certificate could be grounds for revocation of the listing. This document shall be reproduced in its entirety.

# IAPMO RESEARCH AND TESTING, INC.

## CERTIFICATE OF LISTING



Issued To: QIANG YING HOSE FACTORY

Effective Date: April 2021

File Number: 12907

Product: Flexible Water Connectors

Void After: April 2026

This certificate is not evidence of current listing. To verify listing status, visit the IAPMO R&T Product Listing Directory at [pld.iapmo.org](http://pld.iapmo.org)

### Identification:

Manufacturer's name or trademark and cUPC® certification mark. Special note on label "For use with water in exposed locations only."

### Characteristics:

Flexible water connectors manufactured in various sizes, lengths and metal end fittings for hot or cold water applications that consist of an inner tube, which may or may not have an outer braided cover. Connectors are to be installed for use in accessible locations only and in accordance with the manufacturer's instruction, and the latest edition of the Uniform Plumbing Code.

Products listed on this certificate have been tested by an IAPMO R&T recognized laboratory. This recognition has been granted based upon the laboratory's compliance to the applicable requirements of ISO/IEC 17025.

# IAPMO RESEARCH AND TESTING, INC.

5001 E. Philadelphia Street, Ontario, CA 91761 • Phone (909) 472-4100 • Fax (909) 472-4244 • www.iapmort.org



## CERTIFICATE OF LISTING



IAPMO Research and Testing, Inc. is a product certification body in which its product certification system includes inspection and testing of samples taken from the supplier's stock or from the market or a combination of both to verify compliance to the requirements of applicable codes and standards. This activity is coupled with periodic surveillance of the supplier's factory and/or warehouses as well as the assessment of the supplier's Quality Assurance System. This listing is subject to the conditions set forth in the characteristics below and is not to be construed as any recommendation, assurance or guarantee by IAPMO Research and Testing, Inc. of the product acceptance by Authorities Having Jurisdiction.

*Issued To:*

### FOSHAN XIARUN HEALTHTEC CO., LTD.

NO. 2 FACTORY BUILDING, FUWAN HENGMEI VILLAGE, HECHENG STREET, GAOMING FOSHAN , CHINA

*Product:*

### Plumbing Fixture Fittings

*Products are in compliance with the following code(s):*

**Uniform Plumbing Code (UPC®)**  
**National Plumbing Code of Canada**

*Products are certified to the following standard(s)*

**ASME A112.18.1-2018/CSA B125.1-18**

File Number: 14474

Effective Date: June 2023

Void After: June 2028\*

  
Chairman, Product Certification Committee



  
Chief Technical Service Officer

\*This certificate is not evidence of current listing. To verify listing status, visit the IAPMO R&T Product Listing Directory at [pld.iapmo.org](http://pld.iapmo.org)

This listing period is based upon the last date of the month indicated on the Effective Date and Void After Date shown above. Any change in material, manufacturing process, marking or design without having first obtained the approval of the Product Certification Committee, or any evidence of non-compliance with applicable codes and standards or of inferior workmanship, may be deemed sufficient cause for revocation of this listing. Production of or reference to this form for advertising purposes may be made only by specific written permission of IAPMO Research and Testing, Inc. Any alteration of this certificate could be grounds for revocation of the listing. This document shall be reproduced in its entirety.

# IAPMO RESEARCH AND TESTING, INC.

## CERTIFICATE OF LISTING



Issued To: FOSHAN XIARUN HEALTHTEC CO., LTD.

Effective Date: June 2023

File Number: 14474

Product: Plumbing Fixture Fittings

Void After: June 2028

This certificate is not evidence of current listing. To verify listing status, visit the IAPMO R&T Product Listing Directory at [pld.iapmo.org](http://pld.iapmo.org)

### Identification:

Plumbing supply fittings shall be marked with the manufacturer's recognized name, trademark, or other mark or, in the case of private labeling, the name, trademark or other mark of the customer for whom the fitting was manufactured. The marking shall be accomplished by use of a permanent mark or by placing a permanent label on the product. Markings on plumbing supply fittings shall be visible after installation.

Showerheads and hand-held showers shall be marked with the manufacturer's specified maximum flow rate, in L/min and gpm.

Kitchen, lavatory, and metering faucets shall be marked with the manufacturer's specified maximum flow rate, in L/min and gpm or L/cycle and gpc.

Single-handle and single-control bath and shower mixing valves shall have their temperature control settings identified alphabetically, numerically, or graphically.

High-efficiency commercial pre-rinse spray valves shall be marked with the manufacturer's specified maximum flow rate, in L/min (gpm).

Listed products shall bear the cUPC® certification mark.

Packaging for plumbing supply fittings shall be marked with the manufacturer's name, trademark, or other mark as well as the model number or, in the case of private labeling, the name, trademark, or mark of the customer for whom the fitting was manufactured as well as the model number.

Packaging for showerheads and hand-held showers shall be marked with the manufacturer's specified maximum flow rate and either the manufacturer's specified minimum flow rate or the statement "For use with automatic compensating valves rated at xxx L/min (yyy gpm) or less", where xxx L/min (yyy gpm) is the manufacturer's specified minimum flow rate.

Packaging for kitchen, lavatory, and metering faucets shall be marked with the manufacturer's specified maximum flow rate, in L/min and gpm or L/cycle and gpc.

### Characteristics:

Fittings may include lavatory, sink, bath & shower, lawn and sediment faucets. Plumbing fixture fittings to be installed in accordance with the manufacturer's instructions and the requirements of the latest edition of the Uniform Plumbing Code and National Plumbing Code of Canada.

Products listed on this certificate have been tested by an IAPMO R&T recognized laboratory. This recognition has been granted based upon the laboratory's compliance to the applicable requirements of ISO/IEC 17025.



# CERTIFICATE OF COMPLIANCE

**Certificate Number** UL-US-L472949-11-31804102-2  
**Report Reference** E472949-20140813  
**Date** 2-Nov-2023

**Issued to:** T SPA MFG LLC  
10520 Kinghurst St  
Houston, TX 77099  
United States

**This is to certify that  
representative samples of**

QMTX - Plumbing Accessories  
See Addendum Page for Product Designation(s).

Have been evaluated by UL in accordance with the  
Standard(s) indicated on this Certificate.

**Standard(s) for Safety:** UL 1951, 2nd Ed., Revision Date: 2020-06-27

**Additional Information:** See the UL Online Certifications Directory at  
<https://iq.ulprospector.com> for additional information

This Certificate of Compliance indicates that representative samples of the product described in the certification report have met the requirements for UL certification. It does not provide authorization to apply the UL Mark. Only the Authorization Page that references the Follow-Up Services Procedure for ongoing surveillance provides authorization to apply the UL Mark.

Only those products bearing the UL Mark should be considered as being UL Certified and covered under UL's Follow-Up Services.

Look for the UL Certification Mark on the product.

  
Deborah Jennings-Conner, VP Regulatory Services

UL LLC

Any information and documentation involving UL Mark services are provided on behalf of UL LLC (UL) or any authorized licensee of UL. For questions, please contact a local UL Customer Service Representative at <http://ul.com/about/locations/>



# CERTIFICATE OF COMPLIANCE

**Certificate Number** UL-CA-L472949-31-31804102-2  
**Report Reference** E472949-20140813  
**Date** 2-Nov-2023

**Issued to:** T SPA MFG LLC  
10520 Kinghurst St  
Houston, TX 77099  
United States

**This is to certify that representative samples of**

QMTX7 - Plumbing Accessories Certified for Canada  
See Addendum Page for Product Designation(s).

Have been evaluated by UL in accordance with the Standard(s) indicated on this Certificate.

**Standard(s) for Safety:** CSA C22.2 No. 68, 8th Ed., Issue Date: 2018-08, Revision Date: 2019-5

**Additional Information:** See the UL Online Certifications Directory at <https://iq.ulprospector.com> for additional information

This Certificate of Compliance indicates that representative samples of the product described in the certification report have met the requirements for UL certification. It does not provide authorization to apply the UL Mark. Only the Authorization Page that references the Follow-Up Services Procedure for ongoing surveillance provides authorization to apply the UL Mark.

Only those products bearing the UL Mark should be considered as being UL Certified and covered under UL's Follow-Up Services.

Look for the UL Certification Mark on the product.

  
Deborah Jennings-Conner, VP Regulatory Services

UL LLC

Any information and documentation involving UL Mark services are provided on behalf of UL LLC (UL) or any authorized licensee of UL. For questions, please contact a local UL Customer Service Representative at <http://ul.com/about/locations/>



# CERTIFICATE OF COMPLIANCE

**Certificate Number** UL-US-L472949-11-31804102-2  
**Report Reference** E472949-20140813  
**Date** 2-Nov-2023

This is to certify that representative samples of the product as specified on this certificate were tested according to the current UL requirements

<b>Model</b>	<b>Category Description</b>
T-200, T-300, T-700, T-800, T-900	Pedicure Spas, additionally classified in accordance with the water retention requirements of ASME/ANSI A112.19.7M-2006

  
Deborah Jennings-Conner, VP Regulatory Services  
UL LLC



Any information and documentation involving UL Mark services are provided on behalf of UL LLC (UL) or any authorized licensee of UL. For questions, please contact a local UL Customer Service Representative at <http://ul.com/about/locations>

**T-SPA<sup>®</sup>**  
**WWW.TSPALLC.COM**

T-SPA MFG, LLC  
10510 Kinghurst Dr  
Houston, TX 77099  
1(888)508-8772  
Info@tspallc.com